

XPK⁺ / RPK⁺ – Power and precision in a compact design



XPK⁺

New standard now also available as a hypoid version

Both the XP⁺ and RP⁺ Premium planetary gearboxes are now available in a right-angle version with hypoid gearing. The axis offset of hypoid gearboxes allows both higher ratios in one section (ratio $i = 3 - 10$) as well as higher torques compared to bevel gearboxes. The high torque density allows for an extremely compact, space-saving design. The mesh frequency and high torsional rigidity of the gearbox are also extremely impressive since they ensure a higher degree of positioning accuracy and extremely smooth operation.

XPK⁺ and RPK⁺ compared to industry standard

Product highlights

Max. torsional backlash
 XPK⁺ ≤ 4 arcmin (Standard)
 ≤ 2 arcmin (Reduced)
 RPK⁺ ≤ 1.3 arcmin

XPK⁺ and RPK⁺:
Range of transmission ratios: $i = 12 - 5,500$
High axial and radial forces
High torsional rigidity
Maximum performance in small installation space
Optimized for rack and pinion applications
Multiple output configurations for greater flexibility
 Smooth shaft, shaft with key, splined shaft (DIN 5480), blind hollow shaft, flange, System output

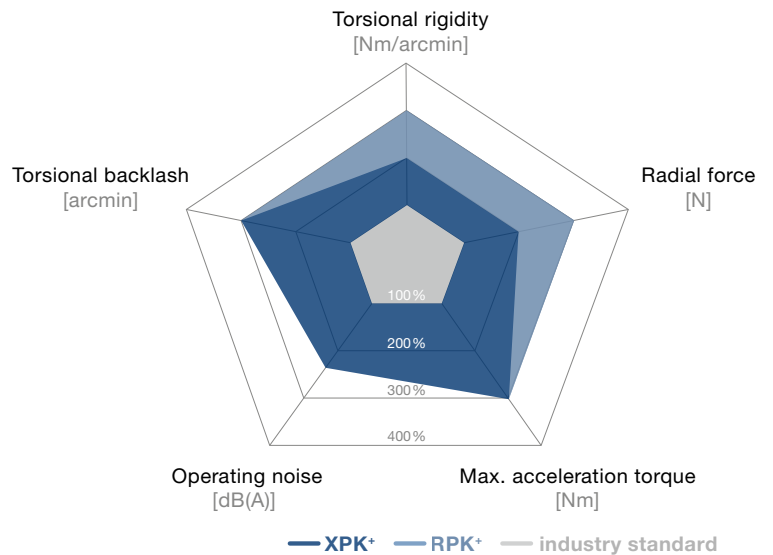

XPK⁺ with pinion and slots

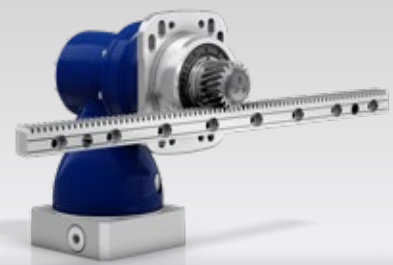

XPK⁺ with pinion, slots and rack

The ideal partnership

Premium Linear Systems with the XPK+ or RPK+ are used in all applications where the individual requirements far exceed what has previously been possible. Compared to the industry standard, the values of the RPK+ have been improved by 150 % on average.

Integrated slots reduce the design and installation requirements to a minimum

High-quality hypoid section with gear ratios of $i = 3 - 10$ in the angle section

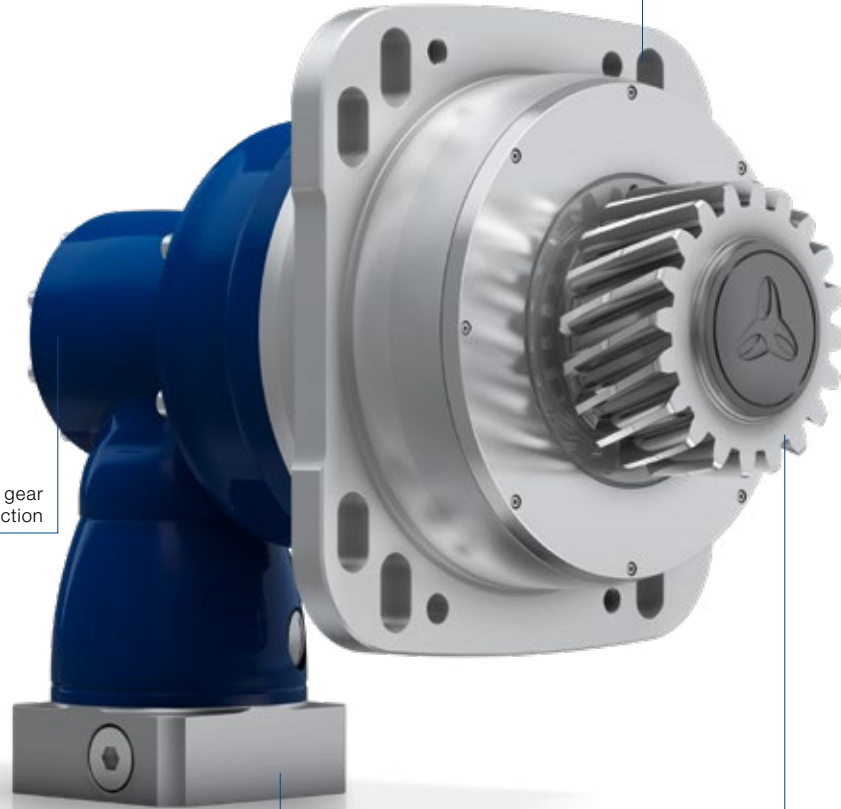

RPK+ with pinion

Metal bellows coupling incorporated for thermal length compensation and protection of the motor bearing

The pinions are specially adapted to the gearbox and allow the transmission of extremely high feed forces



RPK+ with rack and pinion

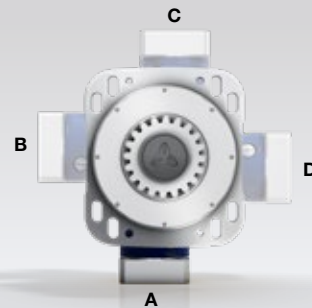

Flexibility during installation

XPK+ 020 MF 2-/3-stage

			2-stage	3-stage
Ratio	i		12 / 16 / 20 / 25 / 28 / 35 / 40 / 50 / 70 / 100	64 / 84 / 100 / 125 / 140 / 175 / 200 / 250 / 280 / 350 / 400 / 500 / 700 / 1000
Max. torque ^{a)}	T_{2a}	<i>Nm</i>	80 – 240	80 – 240
		<i>in.lb</i>	708 – 2124	708 – 2124
Max. acceleration torque (max. 1000 cycles per hour)	T_{2B}	<i>Nm</i>	80 – 180	80 – 180
		<i>in.lb</i>	708 – 1593	708 – 1593
Nominal torque (at n_n)	T_{2N}	<i>Nm</i>	60 – 75	60 – 90
		<i>in.lb</i>	531 – 664	531 – 797
Emergency stop torque (permitted 1000 times during the service life of the gearbox)	T_{2Not}	<i>Nm</i>	160 – 350	160 – 350
		<i>in.lb</i>	1416 – 3098	1416 – 3098
Thermal speed limit (with 20°C ambient temperature and 10% torque utilization) ^{b)}	n_{1T}	<i>rpm</i>	3000 – 3800	5000 – 5500
Max. input speed	n_{1Max}	<i>rpm</i>	7500	6000
Max. torsional backlash	j_t	<i>arcmin</i>	Standard ≤ 5 / Reduced ≤ 3	Standard ≤ 5 / Reduced ≤ 3
Torsional rigidity	C_{t21}	<i>Nm/arcmin</i>	12 – 14	11 – 15
		<i>in.lb/arcmin</i>	106 – 124	97 – 133
Max. tilting moment	M_{2KMax}	<i>Nm</i>	675	675
		<i>in.lb</i>	5974	5974
Operating noise ^{c)}	L_{PA}	<i>dB(A)</i>	≤ 66	≤ 66
Lubrication			Lubricated for life	Lubricated for life
Clamping hub diameter		<i>mm</i>	14 – 19	11 – 14

^{a)} Application-specific design with cymex® – www.wittenstein-cymex.com

^{b)} For higher ambient temperatures, please reduce input speed

^{c)} At reference ratio and reference speed. Ratio-specific values available in cymex®.

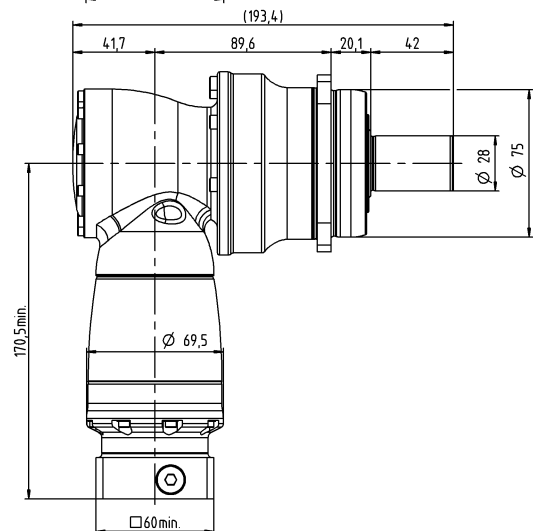
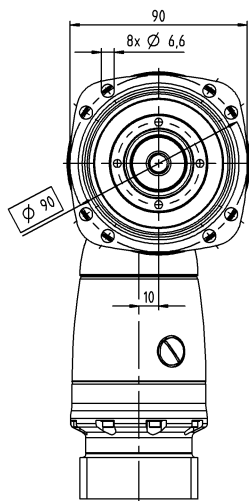
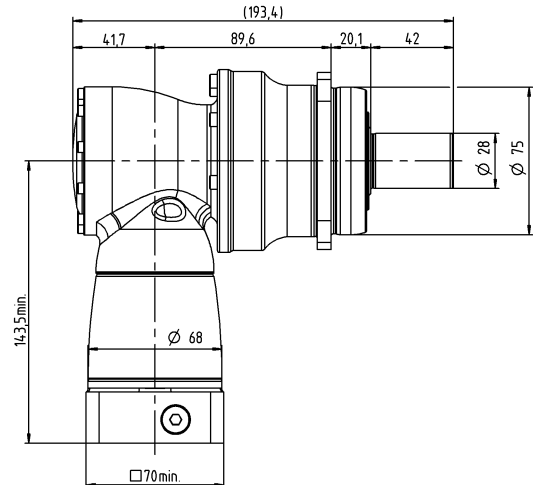
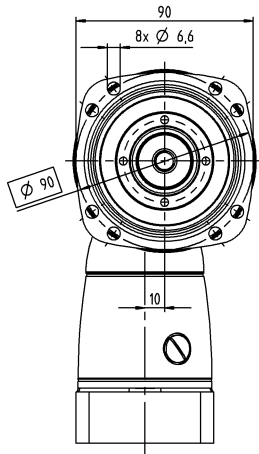

			2-stage	3-stage
Ratio	i		12 / 16 / 20 / 25 / 28 / 35 / 40 / 50 / 70 / 100	64 / 84 / 100 / 125 / 140 / 175 / 200 / 250 / 280 / 350 / 400 / 500 / 700 / 1000
Max. torque ^{a)}	T_{2a}	Nm	200 – 470	200 – 470
		in.lb	1770 – 4160	1770 – 4160
Max. acceleration torque (max. 1000 cycles per hour)	T_{2B}	Nm	200 – 420	200 – 420
		in.lb	1770 – 3717	1770 – 3717
Nominal torque (at n_n)	T_{2N}	Nm	120 – 170	120 – 210
		in.lb	1062 – 1505	1062 – 1859
Emergency stop torque (permitted 1000 times during the service life of the gearbox)	T_{2Not}	Nm	380 – 781	380 – 781
		in.lb	3363 – 6912	3363 – 6912
Thermal speed limit (with 20°C ambient temperature and 10% torque utilization) ^{b)}	n_{TT}	rpm	3000 – 3800	4500
Max. input speed	n_{1Max}	rpm	7500	6000
Max. torsional backlash	j_t	arcmin	Standard ≤ 4 / Reduced ≤ 2	Standard ≤ 4 / Reduced ≤ 2
Torsional rigidity	C_{t21}	Nm/arcmin	29 – 36	29 – 36
		in.lb/arcmin	257 – 319	257 – 319
Max. tilting moment	M_{2KMax}	Nm	1296	1296
		in.lb	11471	11471
Operating noise ^{c)}	L_{PA}	dB(A)	≤ 68	≤ 68
Lubrication			Lubricated for life	Lubricated for life
Clamping hub diameter		mm	19 – 28	14 – 19

^{a)} Application-specific design with cymex® – www.wittenstein-cymex.com

^{b)} For higher ambient temperatures, please reduce input speed

^{c)} At reference ratio and reference speed. Ratio-specific values available in cymex®.

2-stage

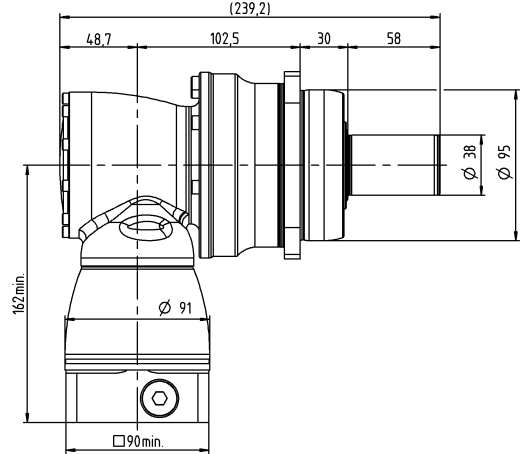
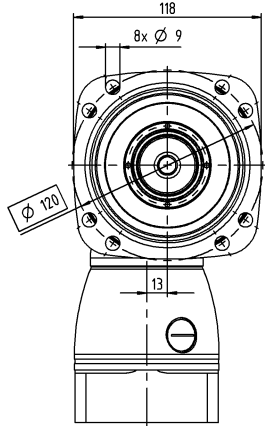

3-stage

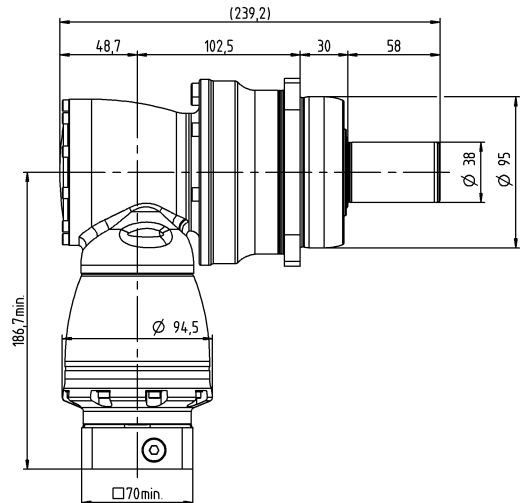
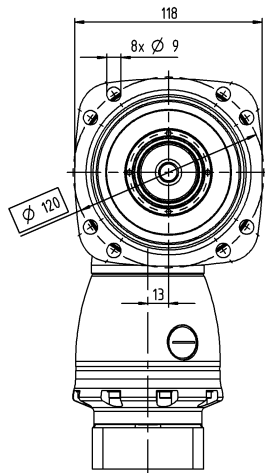

XPK+ 040 MF 2-/3-stage

			2-stage	3-stage
Ratio	i		12 / 16 / 20 / 25 / 28 / 35 / 40 / 50 / 70 / 100	64 / 84 / 100 / 125 / 140 / 175 / 200 / 250 / 280 / 350 / 400 / 500 / 700 / 1000
Max. torque ^{a)}	T_{2a}	Nm	500 – 1020	500 – 1020
		$in.lb$	4425 – 9028	4425 – 9028
Max. acceleration torque (max. 1000 cycles per hour)	T_{2B}	Nm	500 – 850	500 – 850
		$in.lb$	4425 – 7523	4425 – 7523
Nominal torque (at n_n)	T_{2N}	Nm	240 – 370	240 – 400
		$in.lb$	2124 – 3275	2124 – 3540
Emergency stop torque (permitted 1000 times during the service life of the gearbox)	T_{2Not}	Nm	880 – 1820	880 – 1820
		$in.lb$	7789 – 16108	7789 – 16108
Thermal speed limit (with 20°C ambient temperature and 10% torque utilization) ^{b)}	n_{1T}	rpm	2700 – 3500	4000 – 4200
Max. input speed	n_{1Max}	rpm	5500	4500
Max. torsional backlash	j_t	$arcmin$	Standard ≤ 4 / Reduced ≤ 2	Standard ≤ 4 / Reduced ≤ 2
Torsional rigidity	C_{t21}	$Nm/arcmin$	60 – 77	60 – 77
		$in.lb/arcmin$	531 – 682	531 – 682
Max. tilting moment	M_{2KMax}	Nm	1635	1635
		$in.lb$	14471	14471
Operating noise ^{c)}	L_{PA}	$dB(A)$	≤ 70	≤ 70
Lubrication			Lubricated for life	Lubricated for life
Clamping hub diameter		mm	28 – 38	19 – 24

^{a)} Application-specific design with cymex® – www.wittenstein-cymex.com

^{b)} For higher ambient temperatures, please reduce input speed

^{c)} At reference ratio and reference speed. Ratio-specific values available in cymex®.

2-stage

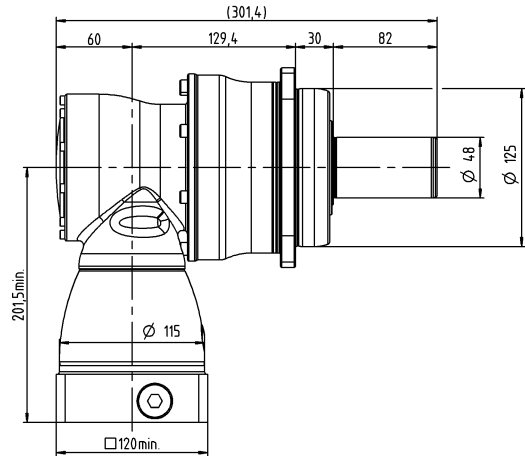
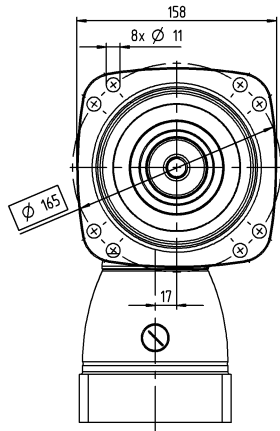

3-stage

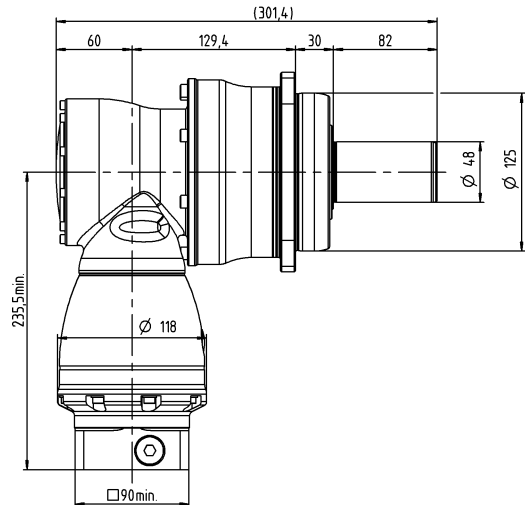
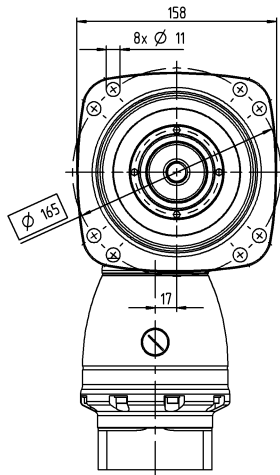

			2-stage	3-stage
Ratio	i		12 / 16 / 20 / 25 / 28 / 35 / 40 / 50 / 70 / 100	64 / 84 / 100 / 125 / 140 / 175 / 200 / 250 / 280 / 350 / 400 / 500 / 700 / 1000
Max. torque ^{a)}	T_{2a}	Nm	840 – 2520	840 – 2520
		in.lb	7435 – 22304	7435 – 22304
Max. acceleration torque (max. 1000 cycles per hour)	T_{2B}	Nm	840 – 2100	840 – 2100
		in.lb	7435 – 18587	7435 – 18587
Nominal torque (at n_n)	T_{2N}	Nm	640 – 750	640 – 1250
		in.lb	5665 – 6638	5665 – 11064
Emergency stop torque (permitted 1000 times during the service life of the gearbox)	T_{2Not}	Nm	1600 – 3505	1600 – 3505
		in.lb	14161 – 31022	14161 – 31022
Thermal speed limit (with 20°C ambient temperature and 10% torque utilization) ^{b)}	n_{TT}	rpm	2300 – 3000	4000 – 4200
Max. input speed	n_{1Max}	rpm	5000	4500
Max. torsional backlash	j_t	arcmin	Standard ≤ 4 / Reduced ≤ 2	Standard ≤ 4 / Reduced ≤ 2
Torsional rigidity	C_{t21}	Nm/arcmin	176 – 224	176 – 226
		in.lb/arcmin	1558 – 1983	1558 – 2000
Max. tilting moment	M_{2KMax}	Nm	3256	3256
		in.lb	28818	28818
Operating noise ^{c)}	L_{PA}	dB(A)	≤ 71	≤ 70
Lubrication			Lubricated for life	Lubricated for life
Clamping hub diameter		mm	38	24 – 38

^{a)} Application-specific design with cymex® – www.wittenstein-cymex.com
^{b)} For higher ambient temperatures, please reduce input speed
^{c)} At reference ratio and reference speed. Ratio-specific values available in cymex®.

2-stage

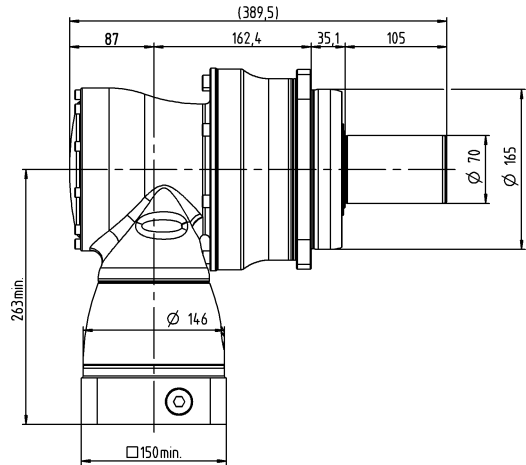
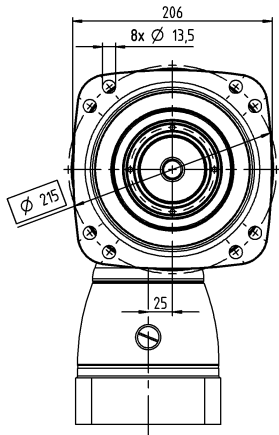

3-stage

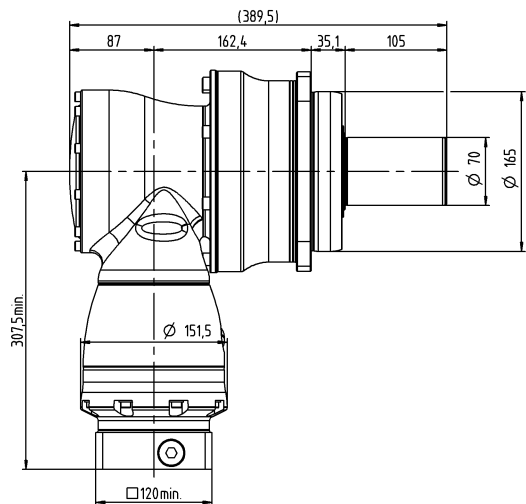
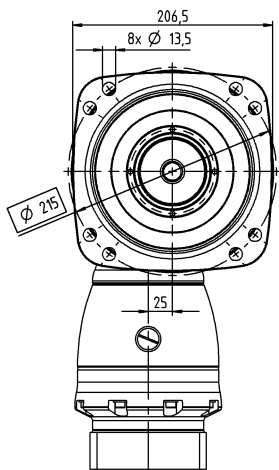

RPK+ 040 MA 3-/4-stage

			3-stage	4-stage
Ratio	i		48 / 66 / 88 / 110 / 137.5 / 154 / 220 / 385	330 / 462 / 577.5 / 770 / 1078 / 1540 / 2695 / 3850 / 5500
Max. torque ^{a)}	T_{2a}	<i>Nm</i>	1100 – 1402	1402
		<i>in.lb</i>	9736 – 12409	12409
Max. acceleration torque (max. 1000 cycles per hour)	T_{2B}	<i>Nm</i>	950	950
		<i>in.lb</i>	8408	8408
Nominal torque (at n_n)	T_{2N}	<i>Nm</i>	675	675
		<i>in.lb</i>	5974	5974
Emergency stop torque (permitted 1000 times during the service life of the gearbox)	T_{2Not}	<i>Nm</i>	1520 – 2613	2090 – 2613
		<i>in.lb</i>	13453 – 23127	18498 – 23127
Thermal speed limit (with 20°C ambient temperature and 10% torque utilization) ^{b)}	n_{1T}	<i>rpm</i>	2800 – 3800	4300 – 4400
Max. input speed	n_{1Max}	<i>rpm</i>	7500	6000
Max. torsional backlash	j_t	<i>arcmin</i>	Standard $\leq 1,3$	Standard $\leq 1,3$
Torsional rigidity	C_{t21}	<i>Nm/arcmin</i>	202 – 215	202 – 217
		<i>in.lb/arcmin</i>	1788 – 1903	1788 – 1921
Max. tilting moment	M_{2KMax}	<i>Nm</i>	3600	3600
		<i>in.lb</i>	31863	31863
Operating noise ^{c)}	L_{PA}	<i>dB(A)</i>	≤ 68	≤ 68
Lubrication			Lubricated for life	Lubricated for life
Clamping hub diameter		<i>mm</i>	19 – 28	14 – 19

^{a)} Application-specific design with cymex® – www.wittenstein-cymex.com

^{b)} For higher ambient temperatures, please reduce input speed

^{c)} At reference ratio and reference speed. Ratio-specific values available in cymex®.

3-stage

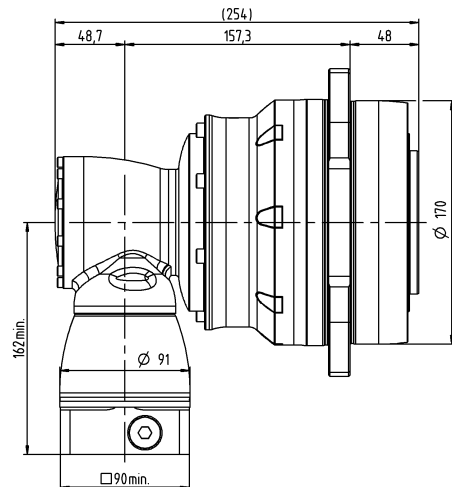
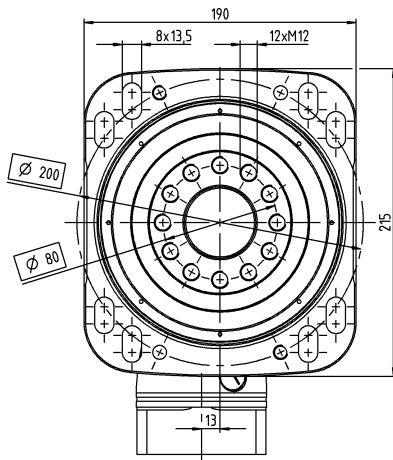

4-stage

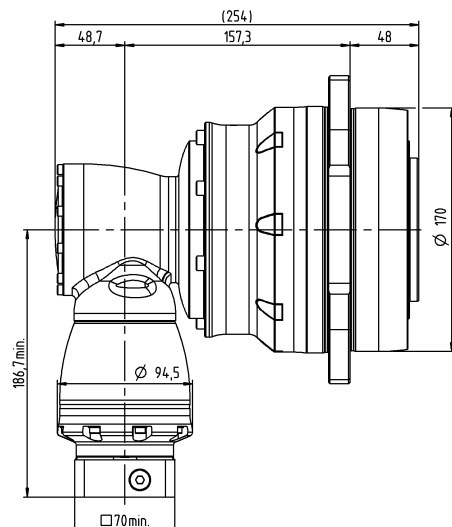
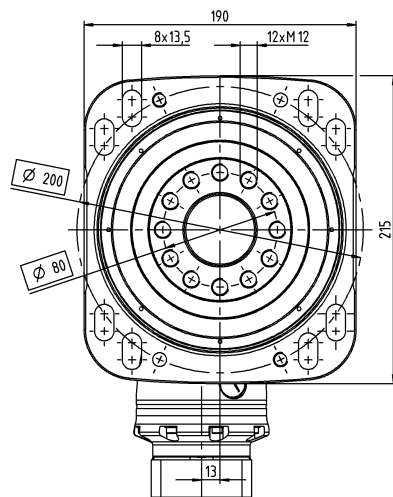

			3-stage	4-stage
Ratio	i		48 / 66 / 88 / 110 / 137.5 / 154 / 220 / 385	330 / 462 / 577.5 / 770 / 1078 / 1540 / 2695 / 3850 / 5500
Max. torque ^{a)}	T_{2a}	Nm	2750 – 3822	3200 – 3822
		in.lb	24340 – 33828	28323 – 33828
Max. acceleration torque (max. 1000 cycles per hour)	T_{2B}	Nm	2720 – 3100	2000 – 3100
		in.lb	24074 – 27437	17702 – 27437
Nominal torque (at n_n)	T_{2N}	Nm	1600 – 1650	1400 – 1650
		in.lb	14161 – 14604	12391 – 14604
Emergency stop torque (permitted 1000 times during the service life of the gearbox)	T_{2Not}	Nm	3520 – 7150	4840 – 7150
		in.lb	31155 – 63283	42838 – 63283
Thermal speed limit (with 20°C ambient temperature and 10% torque utilization) ^{b)}	n_{1T}	rpm	2800 – 3600	3800 – 4100
Max. input speed	n_{1Max}	rpm	5500	4500
Max. torsional backlash	j_t	arcmin	Standard $\leq 1,3$	Standard $\leq 1,3$
Torsional rigidity	C_{t21}	Nm/arcmin	634 – 687	634 – 689
		in.lb/arcmin	5611 – 6080	5611 – 6098
Max. tilting moment	M_{2KMax}	Nm	11000	11000
		in.lb	97359	97359
Operating noise ^{c)}	L_{PA}	dB(A)	≤ 70	≤ 70
Lubrication			Lubricated for life	Lubricated for life
Clamping hub diameter		mm	28 – 38	19 – 24

^{a)} Application-specific design with cymex® – www.wittenstein-cymex.com
^{b)} For higher ambient temperatures, please reduce input speed
^{c)} At reference ratio and reference speed. Ratio-specific values available in cymex®.

3-stage

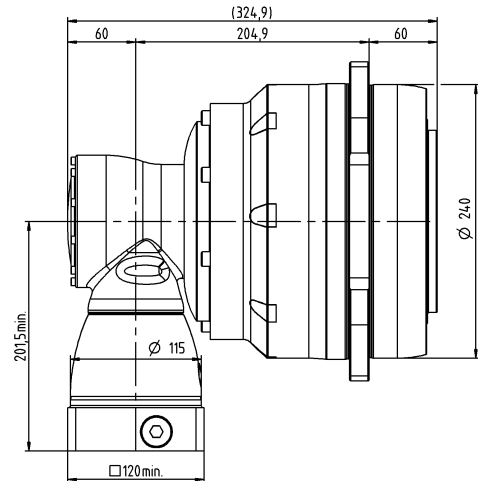
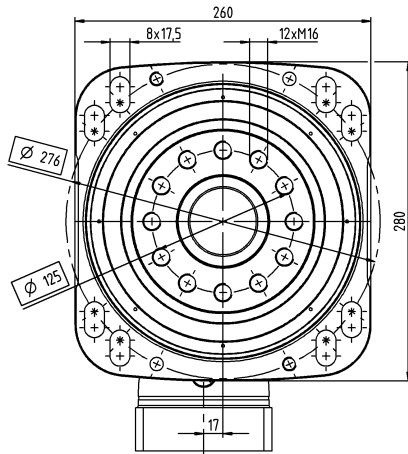

4-stage

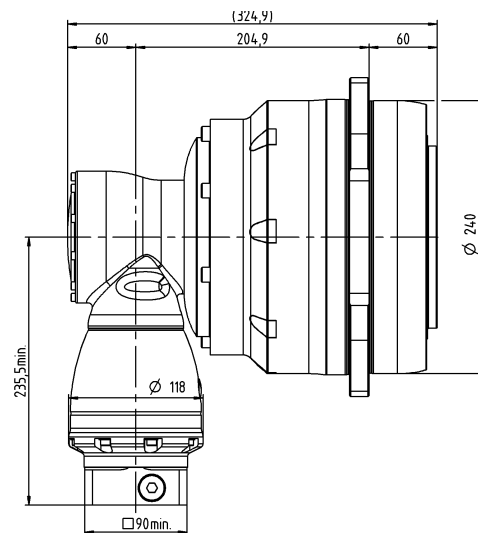
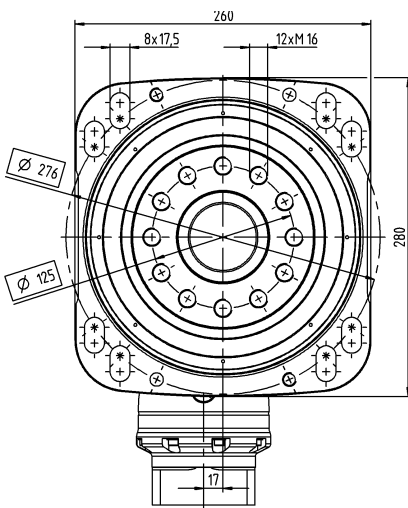

RPK+ 060 MA 3-/4-stage

			3-stage	4-stage
Ratio	i		66 / 88 / 110 / 137.5 / 154 / 220 / 385	330 / 462 / 577.5 / 770 / 1078 / 1540 / 2695 / 3850 / 5500
Max. torque ^{a)}	T_{2a}	Nm	4620 – 7535	6240 – 7535
		in.lb	40891 – 66691	55229 – 66691
Max. acceleration torque (max. 1000 cycles per hour)	T_{2B}	Nm	4620 – 5500	3900 – 5500
		in.lb	30978 – 48679	34518 – 48679
Nominal torque (at n_n)	T_{2N}	Nm	3500	3500
		in.lb	30978	30978
Emergency stop torque (permitted 1000 times during the service life of the gearbox)	T_{2Not}	Nm	8800 – 14575	8800 – 14575
		in.lb	77887 – 129000	77887 – 129000
Thermal speed limit (with 20°C ambient temperature and 10% torque utilization) ^{b)}	n_{1T}	rpm	2300 – 2900	3800 – 4000
Max. input speed	n_{1Max}	rpm	5000	4500
Max. torsional backlash	j_t	arcmin	Standard $\leq 1,8$	Standard $\leq 1,8$
Torsional rigidity	C_{t21}	Nm/arcmin	960 – 1114	953 – 1099
		in.lb/arcmin	8497 – 9860	8435 – 9727
Max. tilting moment	M_{2KMax}	Nm	21000	21000
		in.lb	185867	185867
Operating noise ^{c)}	L_{PA}	dB(A)	≤ 71	≤ 71
Lubrication			Lubricated for life	Lubricated for life
Clamping hub diameter		mm	38	24 – 38

^{a)} Application-specific design with cymex® – www.wittenstein-cymex.com

^{b)} For higher ambient temperatures, please reduce input speed

^{c)} At reference ratio and reference speed. Ratio-specific values available in cymex®.

3-stage

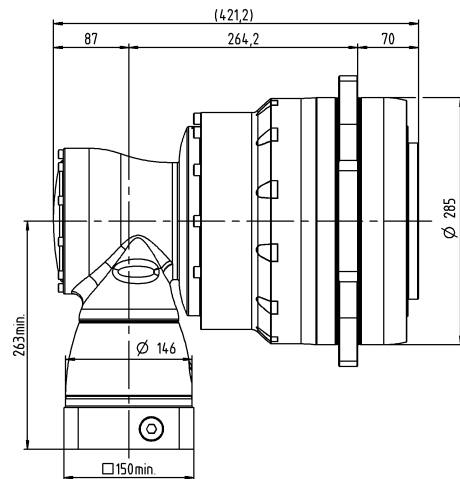
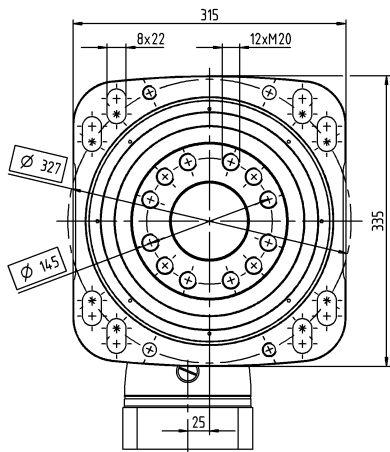

4-stage

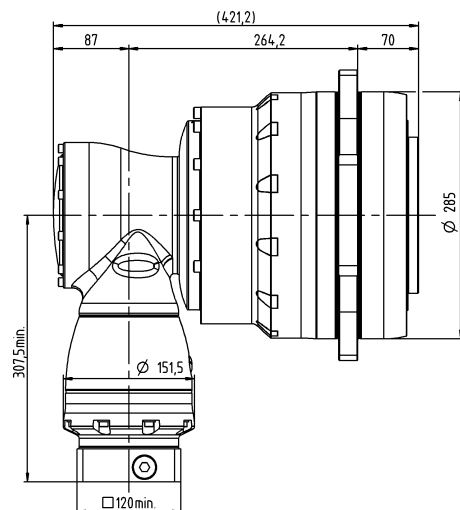
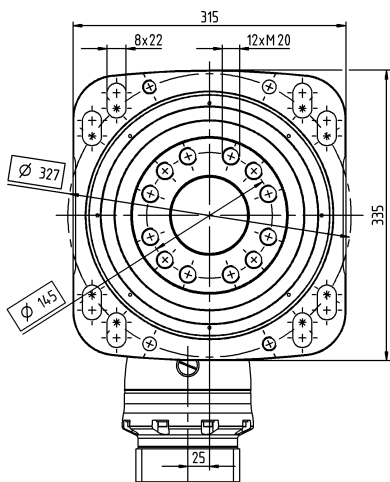

			3-stage	4-stage
Ratio	i		66 / 88 / 110 / 137.5 / 154 / 220 / 385	330 / 462 / 577.5 / 770 / 1078 / 1540 / 2695 / 3850 / 5500
Max. torque ^{a)}	T_{2a}	Nm	10340 – 10450	10450
		in.lb	91517 – 92491	92491
Max. acceleration torque (max. 1000 cycles per hour)	T_{2B}	Nm	10000	7200 – 10000
		in.lb	88508	63726 – 88508
Nominal torque (at n_n)	T_{2N}	Nm	5400	5400
		in.lb	47794	47794
Emergency stop torque (permitted 1000 times during the service life of the gearbox)	T_{2Not}	Nm	19800 – 25000	19800 – 25000
		in.lb	175246 – 221270	175246 – 221270
Thermal speed limit (with 20°C ambient temperature and 10% torque utilization) ^{b)}	n_{TT}	rpm	1800 – 3100	3300 – 3600
Max. input speed	n_{rMax}	rpm	4500	4000
Max. torsional backlash	j_t	arcmin	Standard $\leq 1,8$	Standard $\leq 1,8$
Torsional rigidity	C_{t21}	Nm/arcmin	1747 – 1901	1735 – 1879
		in.lb/arcmin	15462 – 16825	15356 – 16631
Max. tilting moment	M_{2KMax}	Nm	34000	34000
		in.lb	300927	300927
Operating noise ^{c)}	L_{PA}	dB(A)	≤ 71	≤ 71
Lubrication			Lubricated for life	Lubricated for life
Clamping hub diameter		mm	48	38 – 48

^{a)} Application-specific design with cymex® – www.wittenstein-cymex.com
^{b)} For higher ambient temperatures, please reduce input speed
^{c)} At reference ratio and reference speed. Ratio-specific values available in cymex®.

3-stage

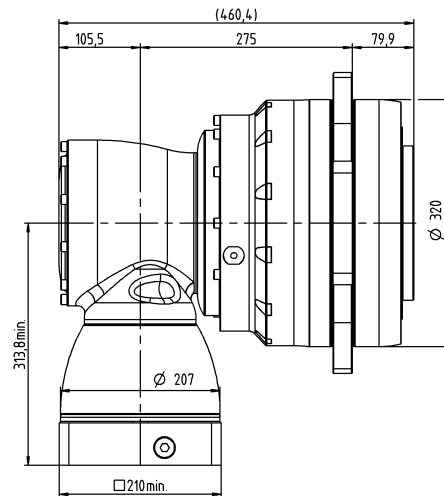
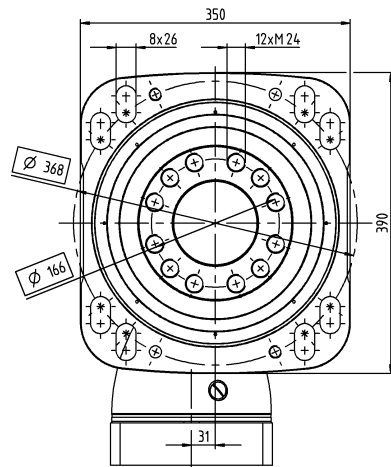

4-stage

