

Technical documents

Hygienic Design HDP⁺ / HDV



WITTENSTEIN alpha GmbH

Walter-Wittenstein-Straße 1
D-97999 Igersheim
Germany

Customer Service department

		✉)
Deutschland	WITTENSTEIN alpha GmbH	service@wittenstein.de	+49 7931 493-12900
Benelux	WITTENSTEIN BVBA	service@wittenstein.biz	+32 9 326 73 80
Brasil	WITTENSTEIN do Brasil	vendas@wittenstein.com.br	+55 15 3411 6454
中国	威腾斯坦（杭州）实业有限公司	service@wittenstein.cn	+86 571 8869 5856
Österreich	WITTENSTEIN GmbH	office@wittenstein.at	+43 2256 65632-0
Danmark	WITTENSTEIN AB	info@wittenstein.dk	+45 4027 4151
France	WITTENSTEIN sarl	info@wittenstein.fr	+33 134 17 90 95
Great Britain	WITTENSTEIN Ltd.	sales.uk@wittenstein.co.uk	+44 1782 286 427
Italia	WITTENSTEIN S.P.A.	info@wittenstein.it	+39 02 241357-1
日本	ヴィッテンシュタイン株式会社	sales@wittenstein.jp	+81-3-6680-2835
North America	WITTENSTEIN holding Corp.	technicalsupport@wittenstein-us.com	+1 630-540-5300
España	WITTENSTEIN S.L.U.	info@wittenstein.es	+34 93 479 1305
Sverige	WITTENSTEIN AB	info@wittenstein.se	+46 40-26 50 10
Schweiz	WITTENSTEIN AG Schweiz	sales@wittenstein.ch	+41 81 300 10 30
台湾	威騰斯坦有限公司	info@wittenstein.tw	+886 3 287 0191
Türkiye	WITTENSTEIN Güç Aktarma Sistemleri Tic. Ltd. Şti.	info@wittenstein.com.tr	+90 216 709 21 23

© WITTENSTEIN alpha GmbH 2022

Subject to technical and content changes without notice.

Table of Contents

1	About this manual	3
1.1	Information symbols and cross references	3
1.2	Scope of delivery	3
2	Safety	4
2.1	Product conformity	4
2.1.1	European Union (EU)	4
2.1.2	United Kingdom (GB)	4
2.2	Personnel	5
2.3	Intended use	5
2.4	Reasonably foreseeable misuse	5
2.5	General safety instructions	6
2.6	Structure of warning instructions.....	6
2.6.1	Safety symbols	7
2.6.2	Signal words.....	7
3	Description of the gearbox	8
3.1	Overview of gearbox components	8
3.1.1	Version with through-holes.....	8
3.1.2	Version with threaded bores.....	9
3.2	Name plate.....	9
3.3	Ordering code	9
3.4	Dimensions and performance data	10
3.5	Information about the lubricant	10
3.6	Notes regarding the IP protection class	10
4	Transport and storage	11
4.1	Packaging	11
4.2	Transport.....	11
4.3	Storage	11
5	Assembly	12
5.1	Preparations.....	12
5.2	Mounting the motor to the gearbox	13
5.3	Mounting the gearbox on a machine.....	16
5.3.1	Mounting with through-holes	16
5.3.2	Mounting with slotted holes	17
5.3.3	Mounting with threaded bores	18
5.4	Components mounted to the output side	18
5.4.1	Mounting with shrink disk	19
6	Startup and operation	20
7	Maintenance and disposal	21
7.1	Maintenance schedule	21
7.2	Maintenance work.....	21
7.2.1	Visual inspection	21
7.2.2	Checking the tightening torques.....	21
7.3	Startup after maintenance work	22
7.4	Disposal	22
8	Malfunctions	23
9	Appendix	24
9.1	Specifications for mounting to a motor.....	24
9.1.1	Specifications for clamping bolt, eccentric [H ₁]	24
9.1.2	Specifications for clamping bolt, central [H ₂]	25
9.2	Specifications for mounting to a machine	25
9.3	Specifications for mounting to the output side	26
9.3.1	Specifications for mounting on the output flange	26

9.3.2 Specifications for mounting to the output shaft.....	26
9.4 Specifications for startup and operation	27
9.4.1 Cleaning agents and cleaning process.....	27
9.5 Tightening torques for common thread sizes in general mechanical engineering	28
9.6 Tightening torques for common thread sizes with corrosion-resistant screw connections.....	29
9.7 Declaration of Conformity HDP ⁺	30
9.8 Declaration of Conformity HDV	31

1 About this manual

This operating manual contains necessary information to safely operate the gearbox.

If this manual is supplied with any amendments (e.g. for special applications), the information in the amendments is primarily and exclusively valid.

WITTENSTEIN alpha GmbH provides this manual for all production sites worldwide. The manufacturer of the product is indicated on the name plate (see chapter 3.2 "Name plate").

The operator must ensure that all persons assigned to install, operate, or maintain the gearbox have read and understood these instructions in full.

Store these instructions within reach of the gearbox.

Inform colleagues who work in the area around the machine about the **safety and warning notices** to avoid injuries.

The original instructions were prepared in German; all other language versions are translations of these instructions.

1.1 Information symbols and cross references

The following information symbols are used:

- Indicates an action to be performed
 - ➔ Indicates the results of an action
- ① Provides additional information about the action

A cross reference refers to the chapter number and the header of the target section (e. g. 2.3 "Intended use").

A cross reference on a table refers to the table number (e. g. Table "Tbl-15").

1.2 Scope of delivery

- Check the completeness of the delivery against the delivery note.
 - ① Missing parts or damage must be notified immediately in writing to the carrier, the insurance company, or **WITTENSTEIN alpha GmbH**.

2 Safety

These instructions, especially the safety and warning notices and the rules and regulations valid for the operating site, must be observed by all persons working with the gearbox.

The following, especially, must be strictly adhered to:

- Observe the instructions for transport and storage.
- Use the gearbox only in accordance with its intended use.
- Carry out maintenance and repair work appropriately and professionally in conformity with the specified intervals.
- Always mount, dismantle, and operate the gearbox properly (e.g. even test run only with secure mounting).
- The manufacturer of the higher-level machine shall, in accordance with its risk assessment, install protective devices and equipment as appropriate to protect the user from the residual hazards of the gearbox. Only operate the gearbox with intact and active protective devices and equipment.
- Only operate the gearbox with the correct lubricant (type and amount).
- Prevent the gearbox from becoming extremely soiled.
- Only carry out modifications or reconstructions when these are approved in writing by the **WITTENSTEIN alpha GmbH**.

Personal injuries or material damage, or other claims arising from non-observance of these minimum requirements, are the sole responsibility of the operator.

In addition to the safety-related information in this manual, also observe any legal and otherwise applicable rules and regulations, particularly for accident prevention (e.g. personal safety equipment) and environmental protection.

2.1 Product conformity

2.1.1 European Union (EU)

Machine safety

The gearbox is within the scope of Directive 2006/42/EC on machinery. According to the Machinery Directive, the gearbox is classified as partly completed machinery. For this reason, it does not bear a CE mark with reference to the Machinery Directive.

The partly completed machinery must not be put into operation before it is verified that the machinery in which the partly completed machinery is to be incorporated complies with the regulations of the Machinery Directive.

The declaration of incorporation for this gearbox can be found in chapter 9 "Appendix".

2.1.2 United Kingdom (GB)

Machine safety

The gearbox is within the scope of the regulation S.I. 2008 No. 1597, Supply of Machinery (Safety) Regulations 2008 According to the Supply of Machinery (Safety) Regulation, the gearbox is classified as partly completed machinery. For this reason, it does not bear a UKCA mark with reference to the Supply of Machinery (Safety) Regulation.

The partly completed machinery must not be put into operation before it is verified that the machinery in which the partly completed machinery is to be incorporated complies with the regulations of the Supply of Machinery (Safety) Regulation.

The declaration of incorporation for this gearbox can be found in chapter 9 "Appendix".

2.2 Personnel

Only technicians who have read and understood this operating manual may perform work on the gearbox. Based on their training and experience, technicians must be able to evaluate the tasks assigned to them, in order to recognize and avoid risks.

2.3 Intended use

The gearbox serves to convert torques and speeds. It is suitable for industrial applications.

The gearbox may not be operated in areas with potentially explosive atmosphere.

In areas coming into contact with the product in the food processing / pharmaceutical / cosmetics industry, the gearbox may only be used next to or under the product area.

- For direct use in the food sector, provide encapsulation of the gearbox and perform a hygiene risk assessment (in accordance with DIN EN 1672-2).

Product-specific deviations regarding the positioning and mounting position are described in chapter 3 "Description of the gearbox".

The gearbox has been constructed according to current technological standards and accepted safety regulations.

- To avoid any hazard to the operator or damage to the machine, use the gearbox only in accordance with its intended use and in a technically flawless and safe condition.
- If you notice any altered operating behavior, check the gearbox in accordance with chapter 8 "Malfunctions".
- Read the general safety instructions before starting any work (see chapter 2.5 "General safety instructions").

The gearbox is intended for installation on motors that:

- correspond to the design B5 (in the event of deviations, consult our Customer Service department [Technical Customer Service department]).
 - have a radial and axial runout tolerance according to DIN EN 50347.
 - have a cylindrical shaft end with tolerance class h6 to k6.
- ① For motor shaft diameter 55 mm and up, m6 is also permissible.

Screw connections between gearbox and attached component such as motors have to be calculated, dimensioned, mounted, and tested according to current technological standards. Use the VDI directives VDI 2862 sheet 2 and VDI 2230 for example.

- ① The tightening torques recommended by us can be found in Chapter 9 "Appendix".

Deviating from the recommendations in Chapter 5 "Assembly", washers may be used if the material of the screw surface features a too low interface pressure.

- ① The hardness of the washer needs to match the property class of the screw.
- ① Take into account the washer for the screw calculation (joint, additional compression set, surface pressure under screw head and under washer).

2.4 Reasonably foreseeable misuse

Any use is prohibited if

- it contradicts the requirements of chapter 2.3 "Intended use",
- it exceeds the permissible technical data, e.g. speed, force and torque load, temperature, service life (see also chapter 3.4 "Dimensions and performance data").

2.5 General safety instructions

The operation of the gearbox involves residual risks even when adhering to the intended use.

Rotating components can cause serious injuries:

- Before startup, remove objects, loose components (e.g. feather keys), and tools from the gearbox, in order to avoid danger from thrown parts.
- Keep a sufficient distance to moving machine components when the gearbox is running.
- Secure the higher-level machine against restarting and unintentional movements during assembly and maintenance work (e.g. uncontrolled lowering of lifting axes).

A **hot gearbox** can cause serious burns:

- Touch the hot gearbox only with protective gloves.

The **noise emissions** can cause hearing damage. The continuous noise pressure level may vary according to product type and gearbox size:

- ① Information about your gearbox is available in the customized performance data (X093–D...), in the catalog under www.wittenstein-alpha.de, or from our Customer Service / Sales department.
- For noise protection measures, observe the total noise pressure level of the machine.

Loose or overloaded screw connections can cause damage to the gearbox:

- Use a calibrated torque wrench to tighten and check all screw connections for which tightening torques have been specified.

Solvents and lubricants are flammable, can cause skin irritation, and can pollute soil and water:

- In case of fire: Do not use a jet of water to extinguish.
 - ① Suitable extinguishing agents are powder, foam, water mist and carbon dioxide. Observe the safety instructions of the lubricant manufacturer (see Chapter 3.5 "Information about the lubricant").
- Use protective gloves to avoid direct skin contact with solvents and lubricants.
- Use and dispose of cleaning solvents and lubricants properly.

A **damaged gearbox** can cause accidents and injury:

- Immediately shut down a gearbox that has been overloaded due to misuse or a machine crash (see Chapter 2.4 "Reasonably foreseeable misuse").
- Replace the damaged gearbox, even if no external damage is visible.

2.6 Structure of warning instructions

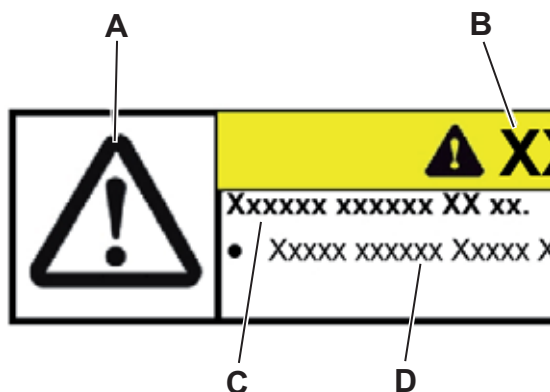

Warning instructions are situation-specific. They will be precisely where tasks are described in which dangers can arise.

The warning instructions in this manual are designed according to the following pattern:

- A** = Safety symbol (see Chapter 2.6.1 "Safety symbols")
- B** = Signal word (see Chapter 2.6.2 "Signal words")
- C** = type and consequence of danger
- D** = avoiding danger

2.6.1 Safety symbols

The following safety symbols are used to indicate possible hazards, prohibitions, and important information:



General hazard



Hot surface



Suspended loads



Entanglement



Environmental protection



Information

2.6.2 Signal words

The following signal words are used to indicate possible hazards, prohibitions, and important information:

	<p style="text-align: center;">⚠ DANGER</p> <p>This signal word indicates an imminent danger that will cause serious injuries or even death.</p>
	<p style="text-align: center;">⚠ WARNING</p> <p>This signal word indicates a potential hazard that could cause serious injuries and even death.</p>
	<p style="text-align: center;">⚠ CAUTION</p> <p>This signal word indicates a potential hazard that could cause minor or serious injuries.</p>
	<p style="text-align: center;">NOTICE</p> <p>This signal word indicates a potential hazard that could lead to material damage.</p>
	<p>A note without a signal word indicates application hints or especially important information for handling the gearbox.</p>

3 Description of the gearbox

The product types HDP⁺ and HDV conform to the **Hygienic Design**. The gearbox may therefore also be used over the product area in food processing / pharmaceutical / cosmetics applications. Product type HDP⁺ is specially optimized for industrial use in delta robots and applications with comparable motion profiles.

The gearbox is a single- or multi-stage low-backlash gearbox. Certain product types may be used only in a defined mounting position.

- Mounting position for HDP⁺: B5 (horizontal), alternative mounting position upon request
- Mounting position for HDV: any

For applications with special safety requirements (e.g. vertical axes, distorted gear inputs) we recommend employing exclusively our product type HDP⁺ or consult **WITTENSTEIN alpha GmbH**.

Various types of motors can be accommodated using

- an adapter plate / adapter flange
- intermediate flange as necessary.
- bushing as necessary.

3.1 Overview of gearbox components

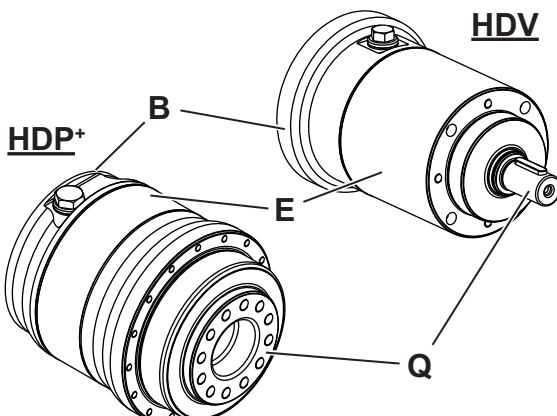
Gearbox components		
	E	Gear housing
	Q	Output shaft / Output flange
	B	Adapter flange / Adapter plate

Tbl-1: Overview of gearbox components HDP⁺ / HDV

3.1.1 Version with through-holes

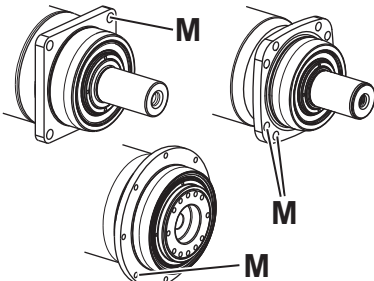
Gearbox components		
	M	Through-holes (see Chapter 5.3.1 "Mounting with through-holes")

Tbl-2: Version with through-holes

3.4 Dimensions and performance data

The dimensions, the maximum permissible speeds and torques, and information on the service life can be found

- in our catalog,
- at www.wittenstein-alpha.de,
- in the specification software **cymex**[®],
- in the respective customized performance data (X093–D...).

① Consult our Customer Service department if the gearbox is older than a year. The user will then receive the valid performance data.

3.5 Information about the lubricant

	<p>The product type HDP⁺ is lubricated ex works for the entire working life with synthetic oil according to NSF H1 approved for the food sector (see name plate).</p> <p>The product type HDV is lubricated ex works for the entire working life with synthetic grease according to NSF H1 approved for the food sector (see name plate)</p> <p>All bearings are lubricated ex works for the entire working life.</p>
---	--

3.6 Notes regarding the IP protection class

	<p>The products comply with the protection class according to the catalog in accordance with EN 60529.</p>
--	--



4 Transport and storage

4.1 Packaging

The gearbox is delivered packed in foil and cardboard boxes.

- Dispose of the packaging materials at the recycling sites intended for this purpose. Observe the applicable national regulations concerning disposal.

4.2 Transport

	<h3>⚠ WARNING</h3>
	<p>Suspended loads can fall and can cause serious injuries and even death.</p> <ul style="list-style-type: none"> • Do not stand under suspended loads. • Secure the gearbox before transport with suitable fasteners (e.g. belts).
	<h3>NOTICE</h3>
	<p>Impacts, for instance from falling or hard dropping, may damage the gearbox.</p> <ul style="list-style-type: none"> • Only use hoisting equipment and lifting accessories with sufficient capacity. • Never exceed the maximum permissible load for hoisting equipment. • Lower the gearbox slowly.

The table "Tbl-5" specifies the maximum gearbox weights. Depending on the version, the actual weight can be considerably less.

Gearbox size HDP⁺	010	025	050
Maximum weight [kg]	7.3	11.1	21.9
Gearbox size HDV	015	025	035
Maximum weight [kg]	3.8	6.5	16.6

Tbl-5: Maximum weight [kg]

No special method is specified for transporting the gearbox.

4.3 Storage

Store the gearbox in horizontal position and dry surroundings at a temperature of 0 °C to +40 °C in the original packaging. Store the gearbox for a maximum of 2 years. Consult our Customer Service department if the conditions are different.

For storage logistics, we recommend the "first in - first out" method.

5 Assembly

- Read the general safety instructions before beginning to work (see Chapter 2.5 "General safety instructions").
- If you have questions about correct mounting, consult our Customer Service department.

5.1 Preparations

	NOTICE
	<p>Pressurized air can damage the gearbox seals.</p> <ul style="list-style-type: none"> • Do not use pressurized air to clean the gearbox.
	<p>Directly sprayed cleaning agents can alter the frictional values of the clamping hub.</p> <ul style="list-style-type: none"> • Only spray cleaning agents onto a cloth for wiping off the clamping hub.

Operation without an adapter plate might lead to damage.

- Only install your own adapter plate or replace an adapter plate according to the specifications of **WITTENSTEIN alpha GmbH**. Our Customer Service department will provide you with disassembly instructions for this purpose.
- Operation without an adapter plate is prohibited.

	<p>In rare cases, seeping may occur at the drive (slight, non-continuous discharge of lubricant). This does not apply to gearboxes in Hygienic Design.</p> <p>For optimized sealing of the motor / gearbox interface, we recommend sealing the surfaces between</p> <ul style="list-style-type: none"> - the adapter plate and drive housing (gearbox), as well as between - the adapter plate and motor, <p>using a surface sealing adhesive (e.g. Loctite® 573 or 574).</p> <p>① For further information, see the separate manuals "Adapter plate replacement" (doc no. 2022-D063062) and "Adapter plate with sealing adhesive" (doc no. 2098-D021746). The manual will be provided by our Sales / Customer Service department on request. Always state the serial number when making the request.</p>
--	---

- Make sure that the motor meets the requirements in chapter 2.3 "Intended use".
- Select the screws for fastening the motor to the adapter plate according to the motor manufacturer's specifications. Observe the minimum screw-in depth in relation to the property class (see table "Tbl-6").

Property class of screws for fastening the motor	8.8	10.9	Ax-70	Ax-80
Minimum screw-in depth	1.5 x d	1.8 x d	1.5 x d (*)	
d = Screw diameter				
(*) Only use a tool that is suitable for working with stainless steel. Valid only for products in Hygienic Design : Use suitable screw head seals.				

Tbl-6: Minimum screw-in depth of screws for fastening the motor to the adapter plate

- Clean / degrease and dry the following components using a clean and lint-free cloth and a grease-dissolving, non-aggressive cleaning agent:
 - All fitting surfaces to neighboring components
 - Centering
 - Motor shaft
 - Inner diameter of clamping hub
 - Bushing, inside and out
- Dry all fitting surfaces to neighboring components to achieve the proper friction values for the screw connections.
- In addition, check the fitting surfaces for damage and impurities.
- Check whether all corrosion protection was removed from all extern components without any residues.

5.2 Mounting the motor to the gearbox

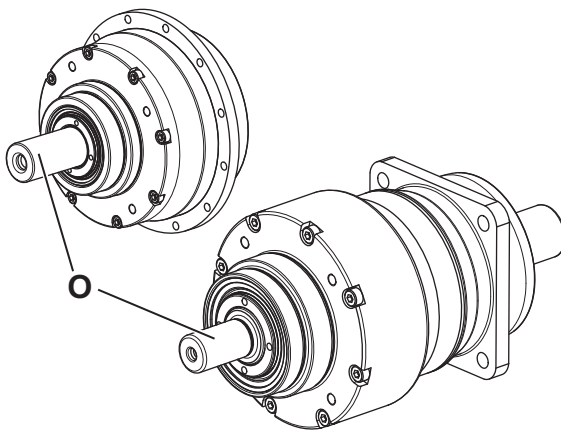

ⓘ **Only** the “self-contained version” gearbox variant with a drive shaft [O] is **not** intended for motor mounting. It is possible to drive the gearbox directly via the drive shaft, e.g. by means of a belt pulley.

For all gearboxes **with** motor-mounting, the following information applies:

- Observe the specifications and safety instructions of the motor manufacturer.
- Observe the safety and processing instructions for the threadlocker to be used.

Valid only for corrosion resistant gearboxes and gearboxes in Hygienic Design:

- Adjust the fitting surface to the gearbox before mounting the motor.
- For **corrosion-resistant** gearboxes, use sealing adhesives (e.g. Loctite[®] 573) to avoid any ingress of foreign media.
- Place an appropriate sealing ring between the adapter plate and motor for gearboxes in **Hygienic Design** to avoid any ingress of foreign media.

ⓘ In addition, **WITTENSTEIN alpha GmbH** offers a suitable sealing plate. For more information, please see the separate manual for "Sealing plate installation" (doc. no 2098–D038000).

The manual can be found in the download area on our website www.wittenstein-alpha.de.

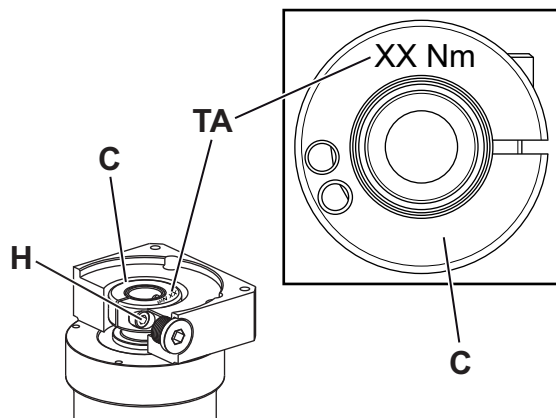

The tightening torque value [TA] of the clamping bolt [H] can be found on the clamping hub [C].

① The value for the tightening torque can also be found in Chapter 9.1 "Specifications for mounting to a motor".

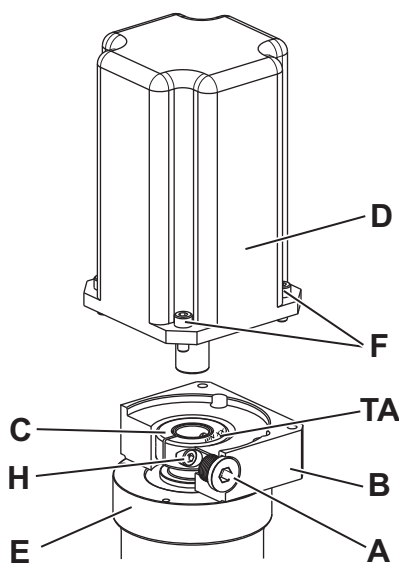

- Preferably, the motor should be mounted in a vertical orientation.
 - Remove the locking screw / set screw / stopper plug [A] from the mounting bore in the adapter plate [B].
 - Rotate the clamping hub [C] until the clamping bolt [H] can be reached via the mounting bore.
 - Loosen the clamping bolt [H] of the clamping hub [C] by one revolution.
 - Slide the motor shaft into the clamping hub of the gearbox [E].
- ① The motor shaft should slide in easily. If this is not the case, the clamping bolt needs to be loosened some more.

① If the clamping bolt [H₁] is loosened too far or removed, the clamping ring [I] can rotate on the clamping hub. Align it so that the clamping bolt [H₁] is in the keyway of the clamping hub (see table "Tbl-7").

① For certain motor shaft diameters and applications, a slotted bushing needs to be installed in addition.

① For the version with **clamping bolt, eccentric [H₁]**:

The slot of the bushing (if present) and the clamping hub must be flush with the groove (if present) of the motor shaft; see Table "Tbl-7".

For the version with **clamping bolt, central [H₂]**:

The slots of the bushing (if present) and clamping hub have to be aligned with the keyway (if present) of the motor shaft and rotated 90° from the clamping bolt, see Table "Tbl-7".

① No gap is permitted between the motor [D] and the adapter plate [B].

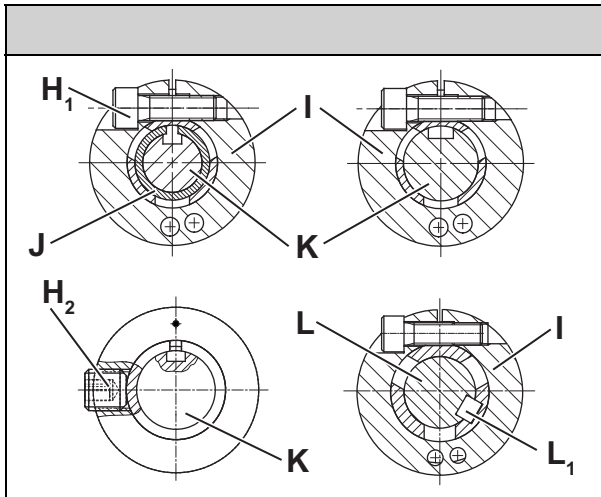
		Designation
	H ₁	Clamping bolt, eccentric
	H ₂	Clamping bolt, central
	I	Clamping ring
	J	Bushing
	K	Keyed motor shaft
	L	Motor shaft with shaft key
	L ₁	Shaft key

Tbl-7: Arrangement of motor shaft, clamping bolt and bushing

- Apply threadlocker (e. g. Loctite® 243) to the four screws [F].
- Fasten the motor [D] onto the adapter plate [B] with the four screws. Evenly tighten the screws crosswise with increasing torque.
- Tighten the clamping bolt [H] of the clamping hub [C].
 - ① The value for the tightening torque can also be found in Chapter 9.1 "Specifications for mounting to a motor".
- For version with
 - **sealing plug**, push it into the adapter plate [B] all the way to the stop.
 - **locking screw** [A₁], screw it into the adapter plate [B].
 - **locking screw with screw head seal** [A₂] (Hygienic Design only), screw it into the adapter plate [B].
 - **set screw** [A₃], screw it flush into the adapter plate [B].
- ① For screw size and specified tightening torque, see table "Tbl-8".

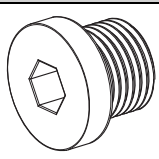
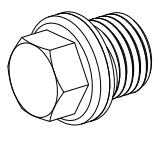
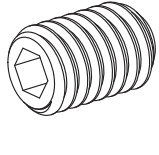
[A]		Width across flats [mm]	Tightening torque [Nm]							
			3	5	6	8	10	12	13	17
A ₁		Locking screw	–	10	–	35	50	70	–	–
A ₂		Locking screw with screw head seal (Hygienic Design only)	–	–	–	–	3	–	5	5.5
A ₃		Set screw	1.5	3	3	6	–	–	–	–

Tbl-8: Tightening torques for the locking screw / set screw

5.3 Mounting the gearbox on a machine

	<ul style="list-style-type: none"> ● Observe the safety and processing instructions for the threadlocker to be used.
--	---

- Center the gearbox in the machine bed.
- Apply threadlocker (e.g. Loctite® 243) to the fastening screws.
- ① Mount the gearbox so that the name plate can still be read.
- ① The specified screw sizes and tightening torques can be found in Chapter 9.2 "Specifications for mounting to a machine".
- ① If your gearbox is equipped with a liquid-cooled adapter plate, the separate instructions "Cooled adapter plate" (doc. no. 2022–D063351) applies. The manual will be provided by our Sales / Customer Service department on request. Please always provide the serial number.
- ① We recommend applying a clearance fit between the mounting flange and centering collar of the gearbox. The mounting flange should have a minimum tolerance of H7.

The following applies only for **Hygienic Design**:

- ① Install the gearbox so that the locking screw faces downwards. This makes cleaning easier.
- ① **WITTENSTEIN alpha GmbH** offers corresponding mounting kits for this. The separate instructions "Hygienic Design Instruction Sheet, Mounting Kit" (Doc. no. 2022–D062618) apply to this. The manual will be provided by our Sales / Customer Service department on request. Please always provide the serial number.

5.3.1 Mounting with through-holes

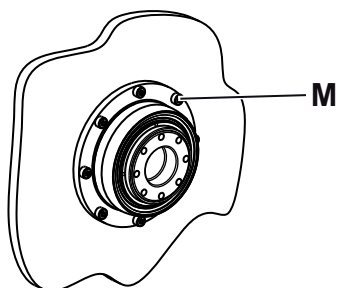

- ① If your gearbox is equipped with reverse centering for motor-side installation [M] on a machine, you will find more information in the separate manual "Reverse centering device for motor-side installation" (doc. no. 2022–D063062). The manual will be provided by our Sales / Customer Service department on request. Please always provide the serial number.

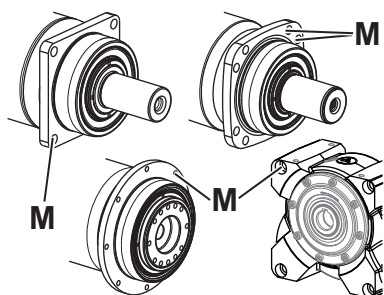

- ① We recommend doing without washers as long as the material of the screw surface features sufficient interface pressure.
- Fasten the gearbox on the machine with the fastening screws through the through-holes [M].

5.3.2 Mounting with slotted holes

- Use only the washers included with the delivery for fastening the gearbox to the machine (see Chapter 9.2 "Specifications for mounting to a machine").

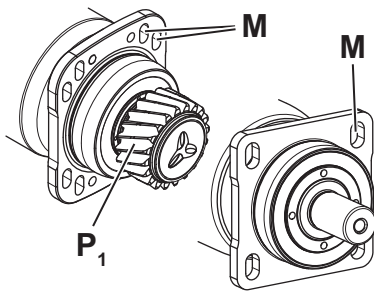

The gearbox can be optionally equipped with an output pinion [P₁]. The gearing backlash between output pinion and toothed rack / counter-wheel can be adjusted using the slotted holes [M] and the lateral guides. An additional adjustment mechanism is no longer necessary.

- ① Detailed information on the design of the gearbox interface is available on request.
- ① For the proper setting of the gearing backlash, you will find further information in the "alpha rack and pinion system" manual (doc. no. 2022-D001333). The manual will be provided by our Sales / Customer Service department on request. Please always provide the serial number.

Operating the gearbox without a motor (e.g. using a hand wheel) is permitted for setting / aligning the output pinion on the toothed rack.

- When doing so, ensure **never** to tilt / bend the clamping hub.

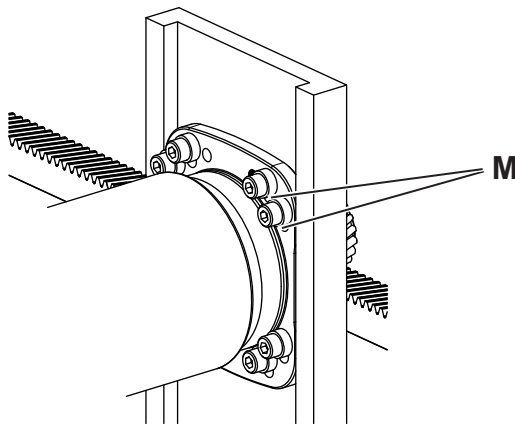

- Slide the washers onto the fastening screws.
- Fasten the gearbox to the machine with the fastening screws through the slotted holes [M].

Pinning the mounted and aligned gearbox (optional)

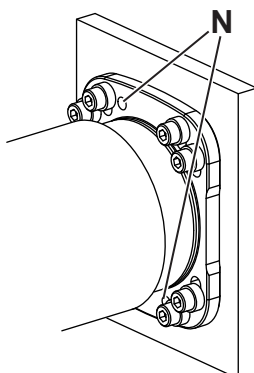

Optionally, there are two bore holes [N] on the gear housing for pinning the gearbox to the machine. You can fasten the gearbox to the machine with cylinder pins.

- Drill pin holes into the machine bed according to the bores [N] of the gear housing.
- Ream the bores to the corresponding fit size for the cylinder pins.
 - ① For specifications on the cylinder pins, refer to Chapter 9.2 "Specifications for mounting to a machine".
- Fasten the gearbox with the cylinder pins.

5.3.3 Mounting with threaded bores

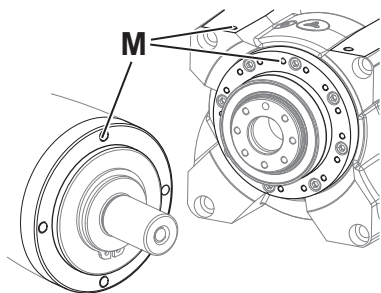

- ① We recommend doing without washers as long as the material of the screw surface features sufficient interface pressure.
- Fasten the gearbox to the machine with the fastening screws through the threaded bores [M].

5.4 Components mounted to the output side

The output side has different shapes depending on the product type:

- Smooth shaft
- Shaft with key
- Splined shaft (DIN 5480)
- Blind hollow shaft / hollow shaft / hollow shaft interface / flanged hollow shaft
- Flange
- with mounted output pinion
- For details on mounting to the **blind hollow shaft / hollow shaft / hollow shaft interface**, refer to the instructions in chapter 5.4.1 "Mounting with shrink disk".
- For details on mounting to the **flange / flanged hollow shaft / keyed hollow shaft**, refer to the instructions in chapter 9.3 "Specifications for mounting to the output side".
- The following only applies to **corrosion-resistant** gearboxes with a **hollow shaft**: Observe the further instructions on sealing in chapter 9.3 "Specifications for mounting to the output side".

	NOTICE
<p>Tension during assembly may damage the gearbox.</p> <ul style="list-style-type: none"> ● Mount the mounting parts onto the output shaft / output flange without using force. ● Never attempt to assemble by force or hammering! ● Only use suitable tools and devices for assembly. ● Make sure not to exceed the maximum permissible static axial forces on the output bearing (see Chapter 9.3 "Specifications for mounting to the output side") when pulling or shrink-fitting a mounting part onto the output side. 	

WITTENSTEIN alpha GmbH offers corresponding mounting kits for gearboxes in **Hygienic Design**. The separate instructions "Hygienic Design Instruction Sheet, Mounting Kit" (Doc. no. 2022-D062618) apply to this. The manual will be provided by our Sales / Customer Service department on request. Please always provide the serial number.

5.4.1 Mounting with shrink disk

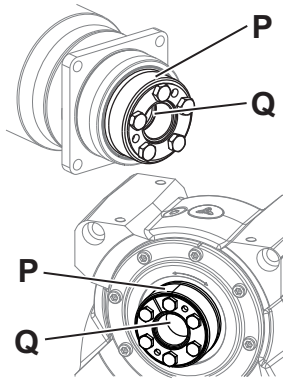

The slip-on shaft / hollow shaft / hollow shaft interface [Q] is axially secured to the load shaft by means of a shrink disk connection. If a gearbox with shrink disk [P] was ordered, then it is already mounted.

- If a different shrink disk is used, observe the instructions of the manufacturer.
- ① With the recommended fit size h6 for the load shaft, it must be possible to push the disk on without exerting force, but without a noticeable fit tolerance. The required dimensions for the slip-on shaft / hollow shaft / hollow shaft interface are found in the catalog (see also Chapter 3.4 "Dimensions and performance data").
- ① Further important instructions on how to handle the shrink disk are found in the separate manual "Shrink disk" (doc. no. 2022-D063039). The manual will be provided by our Sales / Customer Service department on request. Please always provide the serial number.

6 Startup and operation

- Read the general safety instructions before beginning to work (see Chapter 2.5 "General safety instructions").

Improper use can cause damage to the gearbox.

- Ensure that
 - the **ambient temperature** is in the permissible range (see Chapter 9.4 "Specifications for startup and operation") and
 - the **operating temperature** does not exceed +90 °C.
- Avoid freezing, which can damage the seals.
- Use the gearbox only in a clean, dust-free, and dry environment. Moisture penetration in the area of the drive in particular is inadmissible. In this connection, we recommend additional protection measures or alternative products.
- Only use the gearbox up to its maximum limit values, see Chapter 3.4 "Dimensions and performance data". For other conditions of use, consult our Customer Service department.

Valid only for gearboxes in **Hygienic Design**:

- The pump effect of a running gearbox can suck cleaning agents into the gearbox. The gearbox may only be cleaned when it is installed and at standstill.
- High-pressured water jets can damage the gearbox seals and thus lead to leakage.
 - Use a water jet with a **maximum** pressure of 28 bar.
- A roughened surface cannot be cleaned without leaving residues.
 - Take care not to scratch the gearbox.
- Additionally, observe the following instructions for cleaning:
 - Remove applied media from the sealing of the gearbox within 30 minutes.
 - Clean the gearbox with a maximum water temperature of 80 °C.
 - Thoroughly clean all gearboxes over their entire circumference, i.e. everywhere.
 - Use only cleaning processes as described in chapter 9.4 "Specifications for startup and operation".

7 Maintenance and disposal

- Read the general safety instructions before beginning to work (see Chapter 2.5 "General safety instructions").

7.1 Maintenance schedule

Maintenance work	At startup	For the first time after 500 operating hours or 3 months	Every 3 months
Visual inspection	X	X	X
Checking the tightening torques	X		

Tbl-9: Maintenance schedule

7.2 Maintenance work

7.2.1 Visual inspection

- Check the entire gearbox for exterior damage.
- Seals are subject to wear. Therefore, also check the gearbox for leakage during each visual inspection.
 - ① Clean / degrease and dry the seals using a clean and lint-free cloth and a grease-dissolving, non-aggressive cleaning agent: Minimize mechanical effects.
 - ① Check the mounting position to ensure that no foreign media (e.g. oil) or particles (e.g. chips) have collected on the output shaft / output flange.
- The following only applies for **corrosion-resistant** gearboxes: Check the lacquer layer and the nickel-plated surfaces for damages and corrosion.
- Valid only for gearboxes in **Hygienic Design**: Make sure that there is no damage / unevenness or corrosion at any of the surfaces.

7.2.2 Checking the tightening torques

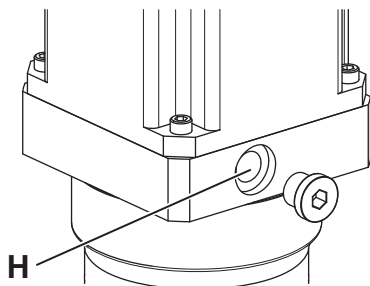

- Check the tightening torque of the clamping bolt [H] on the motor mounting. If, while checking the tightening torque, you discover that the clamping bolt can be turned further, tighten it to the prescribed tightening torque.
 - ① The value for the tightening torque can also be found in Chapter 9.1 "Specifications for mounting to a motor".

Screw connections between gearbox and attached component such as motors have to be calculated, dimensioned, mounted, and tested according to current technological standards. Use the VDI directives VDI 2862 sheet 2 and VDI 2230 for example.

- ① The tightening torques recommended by us can be found in Chapter 9 "Appendix".

Deviating from the recommendations in Chapter 5 "Assembly", washers may be used if the material of the screw surface features a too low interface pressure.

- ① The hardness of the washer needs to match the property class of the screw.
- ① Take into account the washer for the screw calculation (joint, additional compression set, surface pressure under screw head and under washer).

7.3 Startup after maintenance work



- Clean the outside of the gearbox.
- Attach all safety devices.
- Do a trial run before releasing the gearbox again for operation.

7.4 Disposal

Consult our Customer Service department for supplementary information on disassembly and disposal of the gearbox.

- Dispose of the gearbox at the recycling sites intended for this purpose.
 - ① Observe the applicable national regulations concerning disposal.

8 Malfunctions

	NOTICE
	<p>Changed operational behavior can be an indication of existing damage to the gearbox or can cause damage to the gearbox.</p> <ul style="list-style-type: none"> Do not put the gearbox back into operation until the cause of the malfunction has been rectified.
	<p>Rectifying of malfunctions may only be done by specially trained technicians.</p>

Fault	Possible cause	Solution
Increased operating temperature	The gearbox is not suited for the task.	Check the technical data.
	Motor is heating the gearbox.	Check the wiring of the motor.
		Ensure adequate cooling.
	Change the motor.	
	Ambient temperature too high.	Ensure adequate cooling.
Increased operating noises	Tension in motor mounting	Consult our Customer Service department.
	Damaged bearings	
	Toothing damage	
Loss of lubricant	Seeping	Wipe off discharged lubricant and continue to monitor the gearbox. Lubricant discharge should stop after a short time.
	Seals not tight	Consult our Customer Service department.

Tbl-10: Malfunctions

9 Appendix

9.1 Specifications for mounting to a motor

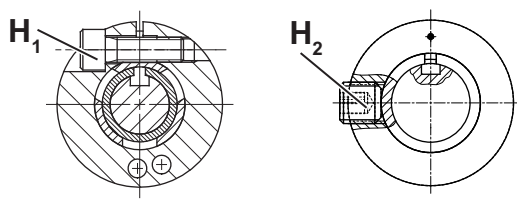
		Designation
	H ₁	Clamping bolt, eccentrical
	H ₂	Clamping bolt, central

Tbl-11: Arrangement of motor shaft, clamping bolt and bushing

9.1.1 Specifications for clamping bolt, eccentrical [H₁]

Tightening torque for clamping bolt (H ₁)					
Ordering code: xxxxxxxx-xxx-xxxxx-x(.)x-xx (see Chapter 3.2 "Name plate")					
Clamping hub Ø ¹⁾ [mm]	(.) [*] Code letter	Width across flats [mm]	Tightening torque [Nm]		
			Coaxial	Angle	
				Coupling "K" 2)	Clamping hub socket "S" 2)
8	Z	2.5	2	—	—
9	A	2.5	2	—	—
11	B	3	4.1	—	4.1
14	C	4	9.5	8.5	9.5
16	D	5	14	14	—
19	E	5	14	14	14
24	G	6	35	35	35
28 ³⁾	H	5	14	—	—
28 ⁴⁾	H	6	—	35	—
32	I	8	79	69	—
38	K	8	79	69	79
48	M	10	135	86	135
55	N	10	135	—	—
60	O	14	330	—	—

¹⁾ The availability of particular clamping hub diameters can be found in the catalog.
²⁾ Ordering code:xxxx-xxx-xxxxx-xxx-x(.); Motor connection
³⁾ only applies for coaxial gearboxes
⁴⁾ only applies for angular gearboxes

Tbl-12: Specifications for clamping bolt, eccentrical [H₁]

9.1.2 Specifications for clamping bolt, central [H₂]

max. clamping hub socket inner Ø [mm]	Width across flats (H ₂) [mm]	Tightening torque [Nm]
14	4	14
19	5	23
24	6	45

Smaller motor shaft diameter is compensated by means of bushing.
If necessary, consult the Customer Service department.

Tbl-13: Specifications for clamping bolt, central [H₂]

9.2 Specifications for mounting to a machine

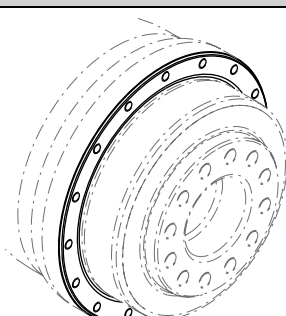
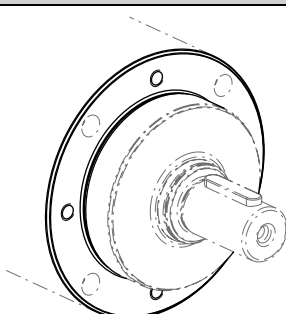
	Gearbox size HDP ⁺	Hole circle Ø [mm]	Quantity x thread x screw depth [] x [mm] x [mm]	Tightening torque [Nm] Property class 12.9
	010	105	16 x M5 x 9	9
	025	125	16 x M5 x 9	9
	050	160	24 x M6 x 13	15.4
	Gearbox size HDV	Hole circle Ø [mm]	Quantity x thread x screw depth [] x [mm] x [mm]	Tightening torque [Nm] Property class Ax-80
	015	62	4 x M5 x 10	4.91
	025	80	4 x M6 x 12	8.42
	035	108	4 x M10 x 20	40

Tbl-14: Specifications for mounting to a machine HDP⁺ / HDV

9.3 Specifications for mounting to the output side

9.3.1 Specifications for mounting on the output flange

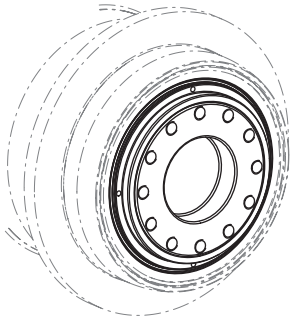
Output flange	Gearbox size HDP ⁺	Hole circle Ø [mm]	Quantity x thread x screw depth [] x [mm] x [mm]	Tightening torque [Nm] Property class 12.9
	010	50	12 x M6 x 10	15.4
	025	63	12 x M8 x 12	37.5
	050	80	12 x M10 x 15	73.5

Tbl-15: Thread in output flange HDP⁺

Maximum permitted axial forces HDP ⁺
Mounting by pressing or shrink-fitting is not intended for this product type.

Tbl-16: Specifications for mounting to the output side

9.3.2 Specifications for mounting to the output shaft

Maximum permitted axial forces HDV			
Ordering code: HDV xxxx-xFx-xxxxx-xxx-xx; Standard			
Gearbox size HDV	015	025	035
$F_{a \max}$ [N]	500	500	1700
Ordering code: HDV xxxx-xTx-xxxxx-xxx-xx; reinforced bearing			
Gearbox size HDV	015	025	035
$F_{a \max}$ [N]	1000	1500	3000

Tbl-17: Maximum permissible static axial forces at static structural safety (s_0) = 1.8 and radial force (RF) = 0

9.4 Specifications for startup and operation

Ambient temperature		
Product type	Minimum temperature [°C]	Maximum temperature [°C]
HDP ⁺ , HDV	-15	+40

Tbl-18: Ambient temperature

9.4.1 Cleaning agents and cleaning process

- Observe the general instructions given in chapter 6 "Startup and operation".

During cleaning or due to the process, the gearbox may be exposed to the following substances or substance mixtures up to a concentration of up to 3 %:

Medium	Formula
Acetyl chloride	CH ₃ COCl
Aluminum chloride	AlCl ₃ ·6H ₂ O
Ammonium chloride	NH ₄ Cl
Antimony chloride	SbCl ₃
Barium chloride	BaCl ₂
Carnallite	KMgCl ₃ ·6H ₂ O
Chlorine (incl. water, limestone and benzene)	Cl ₂
Chlorosulfuric acid	HSO ₃ Cl
Chromic acid	H ₂ CrO _n
Iron(III) chloride	FeCl ₃
Acetic acid	CH ₃ COOH
Hydrogen fluoride	HF
Aqua regia	HNO ₃ + 3HCl
Magnesium chloride	MgCl ₂
Monochloroacetic acid	CH ₂ ClCOOH
Sodium chloride	NaCl
Sodium hydroxide	NaOH
Sodium peroxide	Na ₂ O ₂
Phosphoric acid	H ₃ PO ₄
Sulphuric acid	H ₂ SO ₄
Tartaric acid	C ₄ H ₆ O ₆
Tin(II/IV) chloride	SnCl ₂ ·5H ₂ O(SnCl ₄)

Tbl-19: Cleaning agent positive list

During cleaning or due to the process, the gearbox may **not** be exposed to the following substances or substance mixtures regardless of the concentration:

Substances	Formula
Aniline hydrochloride	C ₆ H ₅ NH ₂ HCl
Bromine	Br ₂
Sodium hypochloride (bleaching lye)	NaClO
Mercury (II) chloride	HgCl ₂
Hydrochloric acid	HCl

Tbl-20: Cleaning agent negative list

Recommended cleaning agents

- For gearbox cleaning, the following cleaning agents from ECOLAB Deutschland GmbH (www.ecolab.eu) were laboratory-tested with regard to surface resistance and sealing materials.
 - Topactive 200 (alkaline foam cleanser), 5% in demineralized water
 - Topactive 500 (acidic foam cleanser), 5% in demineralized water
 - P3-topax 66 (chlorine-alkaline foam disinfectant), 5% in demineralized water
 - P3-topax 990 (mildly alkaline disinfectant cleaner), 3% in demineralized water
 - P3-topactive OKTO (foam disinfectant peracid), 1% in demineralized water

To check the resistance, test samples were placed for 28 days in the indicated test concentration of the respective cleaning agent without mechanical influence in accordance with test method F&E-P3-E no. 40-1.

9.5 Tightening torques for common thread sizes in general mechanical engineering

The specified tightening torques for headless screws and nuts are calculated values and are based on the following conditions:

- Calculation according to VDI 2230 (edition 11/2015)
- Friction value for thread and contact surfaces $\mu=0.10$
- Utilization of the yield stress 90%
- Torque tools type II classes A and D in accordance with ISO 6789

The settings are values rounded to usual commercial scale gradations or settings.

- Use the **exact** values in this table to set your tools.

Property class screw / nut	Tightening torque [Nm] with thread												
	M3	M4	M5	M6	M8	M10	M12	M14	M16	M18	M20	M22	M24
8.8 / 8	1.15	2.64	5.2	9.0	21.5	42.5	73.5	118	180	258	362	495	625
10.9 / 10	1.68	3.88	7.6	13.2	32.0	62.5	108	173	264	368	520	700	890
12.9 / 12	1.97	4.55	9.0	15.4	37.5	73.5	126	202	310	430	605	820	1040

Tbl-21: Tightening torques for set screws and nuts

9.6 Tightening torques for common thread sizes with corrosion-resistant screw connections

The specified tightening torques for screws and nuts are calculated values and are based on the following conditions:

- Calculation based on VDI 2230 (February 2003 issue)
- Friction value for thread and contact surfaces $\mu=0.10$
- Exploitation of the yield stress 90%
- Only valid for:
 - Screws according to ISO 4762, ISO 4014, ISO 4017
 - Nuts according to ISO 4032, ISO 4033

The settings are values rounded to usual commercial scale gradations or setting possibilities.

- Set these values **precisely** on the scale.

Property class screw / nut	Tightening torque [Nm] with thread												
	M3	M4	M5	M6	M8	M10	M12	M14	M16	M18	M20	M22	M24
Ax-50	0.376	0.868	1.72	2.95	7.2	14.0	24.0	38.5	59.0	82.0	115	157	199
Ax-70	0.806	1.86	3.68	6.4	15.2	30.0	51.5	83.0	127	176	248	336	425
Ax-80	1.07	2.48	4.91	8.4	20.5	40.0	69.0	111	169	234	330	450	570

Tbl-22: Tightening torques for screws and nuts made from austenitic steel

9.7 Declaration of Conformity HDP⁺

EG und FDA-Konformitätserklärung EC and FDA-Declaration of Conformity

Wir / We, **WITTENSTEIN alpha GmbH**
 Anschrift / Address Walter-Wittenstein-Straße 1
 D-97999 Igersheim
 Germany
 Tel: +49 (0)700 - 493 10020
 Fax: +49 (0)7931 - 493-200
 e-mail: info-alpha@wittenstein.de

erklären hiermit in alleiniger Verantwortung, dass die außenliegenden Materialien und Schmierstoffe
hereby declare under our sole responsibility, that the external materials and lubricants

der Erzeugnisse
of the products

Bezeichnung: **Hygienic Design Planetengetriebe**
Designation: Hygienic Design Planetary Gear Reducer

Baugröße / Size: **HDP 010, HDP 025, HDP 050**

konform zu der aktuellen Verordnung (EG) Nr. 1935/ 2004, sowie
comply with the current demands on decree (EC) Nr. 1935/ 2004, as well as

konform zu folgenden aktuellen Vorschriften der Food and Drug Administration (FDA) sind:
comply with the current demands on following titles of the Food and Drug Administration (FDA):

Material mit (unvorhersehbaren) Lebensmittelkontakt <i>Material in (unforeseeable) contact with food</i>	Werkstoffbezeichnung <i>material-name</i>	Gruppe von Materialien <i>group of materials</i>	Bemerkungen <i>comments</i>
1.4404 (316 L)	X2CrNiMo17-12-2	Metall <i>metal</i>	Edelstahl <i>stainless steel</i>
1.4418	X4CrNiMo16-5-1	Metall <i>metal</i>	Edelstahl <i>stainless steel</i>
1.4571 (316 Ti)	X6CrNiMoTi17-12-2	Metall <i>metal</i>	Edelstahl <i>stainless steel</i>
FFKM	75 Fluoroprene XP 40	Elastomer <i>elastomer</i>	CFR Title 21 (FDA) § 177.2600
PTFE	PTFE Y002	Polymer <i>polymer</i>	CFR Title 21 (FDA) § 177.1550
Klübersynth UH1 6-220	-	Schmierstoff <i>lubricant</i>	CFR Title 21 (FDA) § 178.3570
Klübersynth UH1 64-1302	-	Schmierstoff <i>lubricant</i>	CFR Title 21 (FDA) § 178.3570

Igersheim, 05.06.2015

Ort und Datum der Ausstellung
Place and Date of Issue

 Dr. Michael Engelbreit
 Konstruktionsleiter / Design Manager

 Rolf Reckels
 Qualitätsmanagement / Quality Manager

Ausgabedatum: 05.06.2015

Dok.-Nr.: 2097-D053985

Rev.: 01

Seite 1 von 1

Ersteller: BAN1 / EA Walpha

9.8 Declaration of Conformity HDV



EG und FDA-Konformitätserklärung EC and FDA-Declaration of Conformity

Wir / We, **WITTENSTEIN alpha GmbH**
 Anschrift / Address Walter-Wittenstein-Straße 1
 D-97999 Igersheim
 Germany
 Tel: +49 (0)700 - 493 10020
 Fax: +49 (0)7931 - 493-200
 e-mail: info-alpha@wittenstein.de

erklären hiermit in alleiniger Verantwortung, dass die außenliegenden Materialien und Schmierstoffe
hereby declare under our sole responsibility, that the external materials and lubricants

der Erzeugnisse
of the products

Bezeichnung: **Hygienic Design Planetengetriebe**
Designation: Hygienic Design Planetary Gear Reducer

Baugröße / Size: **HDV 015, HDV 025, HDV 035**

konform zu der aktuellen Verordnung (EG) Nr. 1935/ 2004, sowie
comply with the current demands on decree (EC) Nr. 1935/ 2004, as well as

konform zu folgenden aktuellen Vorschriften der Food and Drug Administration (FDA) sind:
comply with the current demands on following titles of the Food and Drug Administration (FDA):

Material mit (unvorhersehbaren) Lebensmittelkontakt <i>Material in (unforeseeable) contact with food</i>	Werkstoffbezeichnung <i>material-name</i>	Gruppe von Materialien <i>group of materials</i>	Bemerkungen <i>comments</i>
1.4404 (316 L)	X2CrNiMo17-12-2	Metall <i>metal</i>	Edelstahl <i>stainless steel</i>
1.4418	X4CrNiMo16-5-1	Metall <i>metal</i>	Edelstahl <i>stainless steel</i>
1.4571 (316 Ti)	X6CrNiMoTi17-12-2	Metall <i>metal</i>	Edelstahl <i>stainless steel</i>
FFKM	75 Fluoroprene XP 40	Elastomer <i>elastomer</i>	CFR Title 21 (FDA) § 177.2600
PTFE	PTFE Y002	Polymer <i>polymer</i>	CFR Title 21 (FDA) § 177.1550
Klübersynth UH1-151	-	Schmierstoff <i>lubricant</i>	CFR Title 21 (FDA) § 178.3570
BARRIERA L55/2	-	Schmierstoff <i>lubricant</i>	CFR Title 21 (FDA) § 178.3570

Igersheim, 22.08.2014
 Ort und Datum der Ausstellung
Place and Date of Issue

 Dr. Michael Engelbreit
 Konstruktionsleiter / Design Manager

 Rolf Reckels
 Qualitätsmanagement / Quality Manager

Ausgabedatum: 22.08.2014
 Ersteller: BAN1 / EA Walpha

Dok.-Nr.: 2097-D048598

Rev.: 02

Seite 1 von 1

9.9 Declaration of Conformity

**Einbauerklärung**

(Originaltext)

Wir WITTENSTEIN alpha GmbH
 Walter-Wittenstein-Straße 1
 97999 Igersheim
 GERMANY

erklären als Hersteller, dass die unten bezeichnete unvollständige Maschine den nachfolgend aufgeführten Sicherheits- und Gesundheitsschutzanforderungen der Richtlinie 2006/42/EG Anhang I entspricht (siehe „Anhang zur Einbauerklärung“).

Bezeichnung: **Getriebe**

Ausführung: CP, CP Gen 2, CPK, CPS, CPSK, DP+, DPK+, KPG, PKF+, HDP, HDV, HG+, LK+, LPB, LPB+, LPBK+, LPK+, NP, NPK, NPL, NPLK, NPR, NPRK, NPS, NPSK, NPT, NPTK, RP+, RPC+, RPK+, SC+, SK, SK+, SP, SP+, SPC+, SPK, SPK+, TK+, TP, TP+, TPC+, TPK, TPK+, VDH+, VDS+, VDT+, VH+, VS+, VT+, CVH, CVS, NVH, NVS, VDHe, VDSe, XP, XPC+, XPK+

Seriennummer:	SN: 7386950, 7-8stellig fortlaufend
Einschlägige EG-Richtlinie:	2006/42/EG (Maschinen)
Angewandte harmonisierte Normen:	EN 60529:1991 + A1:2000 + A2:2013 EN ISO 12100:2010
Bevollmächtigter für die Zusammenstellung der technischen Unterlagen:	WITTENSTEIN alpha GmbH (Adresse siehe oben)

Die speziellen technischen Unterlagen gemäß Anhang VII Teil B der Maschinenrichtlinie 2006/42/EG wurden erstellt. Wir verpflichten uns, die speziellen technischen Unterlagen den einzelstaatlichen Stellen auf begründetes Verlangen innerhalb einer angemessenen Zeit in elektronischer Form zu übermitteln.

Die unvollständige Maschine darf erst dann in Betrieb genommen werden, wenn gegebenenfalls festgestellt wurde, dass die Maschine, in die die unvollständige Maschine eingebaut werden soll, den Bestimmungen der Maschinenrichtlinie entspricht.

Igersheim, den 06.12.2022
 Ort und Datum der Ausstellung



 Norbert Pastoors, Geschäftsführer

Document No.: 1000117477

Rev.:01



Anhang zur Einbauerklärung

Liste der für das in der Einbauerklärung angegebene Produkt angewandten und eingehaltenen grundlegenden Sicherheits- und Gesundheitsschutzanforderungen für Konstruktion und Bau von Maschinen.

Kapitel	Bezeichnung	Nicht anwendbar	Eingehalten	Bemerkung
1.1.	Allgemeines			
1.1.1.	Begriffsbestimmungen		x	
1.1.2.	Grundsätze für die Integration der Sicherheit		x	
1.1.3.	Materialien und Produkte		x	
1.1.4.	Beleuchtung	x		
1.1.5.	Konstruktion der Maschine in Hinblick auf die Handhabung		x	
1.1.6.	Ergonomie	x		
1.1.7.	Bedienungsplätze	x		
1.1.8.	Sitze	x		
1.2.	Steuerungen und Befehlseinrichtungen			
1.2.1.	Sicherheit und Zuverlässigkeit von Steuerungen	x		
1.2.2.	Stellteile	x		
1.2.3.	Ingangsetzen	x		
1.2.4.	Stillsetzen	x		
1.2.4.1.	Normales Stillsetzen	x		
1.2.4.2.	Betriebsbedingtes Stillsetzen	x		
1.2.4.3.	Stillsetzen im Notfall	x		
1.2.4.4.	Gesamtheit von Maschinen	x		
1.2.5.	Wahl der Steuerungs- oder Betriebsarten	x		
1.2.6.	Störung der Energieversorgung	x		
1.3.	Schutzmassnahmen gegen mechanische Gefährdungen			
1.3.1.	Verlust Standsicherheit		x	
1.3.2.	Bruchrisiko beim Betrieb		x	
1.3.3.	Risiken durch herabfallende oder herausgeschleuderte Gegenstände	x		
1.3.4.	Risiken durch Oberflächen, Ecken, Kanten		x	
1.3.5.	Risiken durch mehrfach kombinierte Maschinen	x		
1.3.6.	Risiken durch Änderung der Verwendungsbedingungen	x		
1.3.7.	Risiken durch bewegliche Teile	x		
1.3.8.	Wahl der Schutzeinrichtungen gegen Risiken durch bewegliche Teile	x		
1.3.8.1.	Bewegliche Teile der Kraftübertragung	x		

Document No.: 1000117477

Rev.:01



Kapitel	Bezeichnung	Nicht anwendbar	Eingehalten	Bemerkung
1.3.8.2.	Bewegliche Teile die am Arbeitsprozess beteiligt sind	x		
1.3.9.	Risiko unkontrollierter Bewegungen	x		
1.4.	Anforderungen an Schutzeinrichtungen			
1.4.1.	Allgemeine Anforderungen an Schutzeinrichtungen	x		
1.4.2.	Besondere Anforderungen an trennende Schutzeinrichtungen	x		
1.4.2.1.	Feststehende trennende Schutzeinrichtungen	x		
1.4.2.2.	Bewegliche trennende Schutzeinrichtungen mit Verriegelung	x		
1.4.2.3.	Zugangsbeschränkte verstellbare Schutzeinrichtungen	x		
1.4.3.	Besondere Anforderungen an nichttrennende Schutzeinrichtungen	x		
1.5.	Risiken durch sonstige Gefährdungen			
1.5.1.	Elektrische Energieversorgung	x		
1.5.2.	Statische Elektrizität		x	
1.5.3.	Nichtelektrische Energieversorgung	x		
1.5.4.	Montagefehler		x	
1.5.5.	Extreme Temperaturen		x	
1.5.6.	Brand	x		
1.5.7.	Explosion	x		
1.5.8.	Lärm		x	
1.5.9.	Vibration		x	
1.5.10.	Strahlung	x		
1.5.11.	Strahlung von außen	x		
1.5.12.	Laserstrahlung	x		
1.5.13.	Emission gefährlicher Werkstoffe und Substanzen		x	
1.5.14.	Risiko, in einer Maschine eingeschlossen zu werden	x		
1.5.15.	Ausrutsch, Stolper, Sturzrisiko	x		
1.5.16.	Blitzschlag	x		
1.6.	Instandhaltung			
1.6.1.	Wartung der Maschine		x	
1.6.2.	Zugang zu Bedienständen und den Eingriffspunkten für die Instandhaltung	x		
1.6.3.	Trennung von Energiequellen	x		
1.6.4.	Eingriffe des Bedienpersonals	x		
1.6.5.	Reinigung innenliegender Maschinenteile	x		
1.7.	Informationen			
1.7.1.	Informationen und Warnhinweise an der Maschine		x	



Kapitel	Bezeichnung	Nicht anwendbar	Eingehalten	Bemerkung
1.7.1.1.	Informationen und Informationseinrichtungen	x		
1.7.1.2.	Warneinrichtungen	x		
1.7.2.	Warnung vor Restrisiken		x	
1.7.3.	Kennzeichnung der Maschine		x	
1.7.4.	Betriebsanleitung		x	
1.7.4.1.	Allgemeine Grundsätze für die Abfassung einer Betriebsanleitung		x	
1.7.4.2.	Inhalt der Montageanleitung		x	
1.7.4.3.	Verkaufsprospekte		x	

Document No.: 1000117477

Rev.:01



Declaration of Incorporation

(Translation of original text)

We, **WITTENSTEIN alpha GmbH**
 Walter-Wittenstein-Straße 1
 97999 Igersheim
 GERMANY

hereby declare that the partly completed machinery designated below is in conformity with the safety and health protection requirements of Directive 2006/42/EC, Annex I (refer to "Appendix regarding the Declaration of Incorporation").

Description: **Gearbox**

Model: CP, CP Gen 2, CPK, CPS, CPSK, DP+, DPK+, KPG, PKF+, HDP, HDV, HG+, LK+, LPB, LPB+, LPBK+, LPK+, NP, NPK, NPL, NPLK, NPR, NPRK, NPS, NPSK, NPT, NPTK, RP+, RPC+, RPK+, SC+, SK, SK+, SP, SP+, SPC+, SPK, SPK+, TK+, TP, TP+, TPC+, TPK, TPK+, VDH+, VDS+, VDT+, VH+, VS+, VT+, CVH, CVS, NVH, NVS, VDHe, VDSe, XP, XPC+, XPK+

Serial number: SN: 7386950, consecutive number (7-8 digits)

Relevant EC Directive: 2006/42/EC (Machinery)

Applied harmonized standards: EN ISO 12100:2010
 EN 60529:1991 + A1:2000 + A2:2013

The person authorized to compile technical documents: WITTENSTEIN alpha GmbH
 (address see above)

The special technical documentation in accordance with appendix VII part B of directive 2006/42/EG have been created. We undertake to forward the special technical documentation to a reasoned request to the national authorities. We shall submit them by means of electronic data carrier.

The designated partly completed machinery must not be put into service until the final machinery into which it is to be incorporated has been declared in conformity with the provisions of this Directive.

Igersheim, 06.12.2022

City and date



Norbert Pastoors, Managing Director

Document No.: 1000117477

Rev.: 01



Appendix regarding the Declaration of Incorporation

List of the essential health and safety requirements applied and fulfilled for the product named in the Declaration of Incorporation.

Chapter	Designation	not applicable	fulfilled	remark
1.1.	General Remarks			
1.1.1.	Definitions		x	
1.1.2.	Principles of safety integration		x	
1.1.3.	Materials and products		x	
1.1.4.	Lighting	x		
1.1.5.	Design of machinery to facilitate its handling		x	
1.1.6.	Ergonomics	x		
1.1.7.	Operating positions	x		
1.1.8.	Seating	x		
1.2.	Control systems			
1.2.1.	Safety and reliability of control systems	x		
1.2.2.	Control devices	x		
1.2.3.	Starting	x		
1.2.4.	Stopping	x		
1.2.4.1.	Normal stop	x		
1.2.4.2.	Operational stop	x		
1.2.4.3.	Emergency stop	x		
1.2.4.4.	Assembly of machinery	x		
1.2.5.	Selection of control or operating modes	x		
1.2.6.	Failure of the power supply	x		
1.3.	Protection against mechanical hazards			
1.3.1.	Risk of loss of stability		x	
1.3.2.	Risk of break-up during operation		x	
1.3.3.	Risks due to falling or ejected objects	x		
1.3.4.	Risks due to surfaces, edges or angles		x	
1.3.5.	Risks related to combined machinery	x		
1.3.6.	Risks related to variations in operating conditions	x		
1.3.7.	Risks related to moving parts	x		
1.3.8.	Choice of protection against risks arising from moving parts	x		
1.3.8.1.	Moving transmission parts	x		
1.3.8.2.	Moving parts involved in the process	x		
1.3.9.	Risks of uncontrolled movements	x		

Document No.: 1000117477

Rev.: 01



Chapter	Designation	not applicable	fulfilled	remark
1.4.	Required characteristics of guards and protective devices			
1.4.1.	General requirements	x		
1.4.2.	Special requirements for guards	x		
1.4.2.1.	Fixed guards	x		
1.4.2.2.	Interlocking movable guards	x		
1.4.2.3.	Adjustable guards restricting access	x		
1.4.3.	Special requirements for protective devices	x		
1.5.	Risks due to other hazards			
1.5.1.	Electricity supply	x		
1.5.2.	Static electricity		x	
1.5.3.	Energy supply other than electricity	x		
1.5.4.	Errors of fitting		x	
1.5.5.	Extreme temperatures		x	
1.5.6.	Fire	x		
1.5.7.	Explosion	x		
1.5.8.	Noise		x	
1.5.9.	Vibrations		x	
1.5.10.	Radiation	x		
1.5.11.	External radiation	x		
1.5.12.	Laser radiation	x		
1.5.13.	Emissions of hazardous materials and substances		x	
1.5.14.	Risk of being trapped in a machine	x		
1.5.15.	Risk of slipping, tripping or falling	x		
1.5.16.	Lightning	x		
1.6.	Maintenance			
1.6.1.	Machinery maintenance		x	
1.6.2.	Access to operating positions and servicing points	x		
1.6.3.	Isolation of energy sources	x		
1.6.4.	Operator intervention	x		
1.6.5.	Cleaning of internal parts	x		
1.7.	Information			
1.7.1.	Information and warnings on the machinery		x	
1.7.1.1.	Information and information devices	x		
1.7.1.2.	Warning devices	x		
1.7.2.	Warning of residual risks		x	
1.7.3.	Marking of machinery		x	

Document No.: 1000117477

Rev.: 01



Chapter	Designation	not applicable	fulfilled	remark
1.7.4.	Instructions		x	
1.7.4.1.	General principles for the drafting of instructions		x	
1.7.4.2.	Contents of the instructions		x	
1.7.4.3.	Sales literature		x	

Document No.: 1000117477

Rev.: 01



Declaration of Incorporation

(Translation of original text)

We, **WITTENSTEIN alpha GmbH**
 Walter-Wittenstein-Straße 1
 97999 Igersheim
 GERMANY

with our authorized **WITTENSTEIN Ltd.**
 representative for GB, Unit 3 The Glades, Festival Way
 ST1 5SQ Stoke on Trent, Staffordshire, GB

hereby declare that the partly completed machinery designated below is in conformity with the safety and health protection requirements of S.I. 2008:1597, Annex I (refer to "Appendix regarding the Declaration of Incorporation").

Description: **Gearbox**

Model: CP, CP Gen 2, CPK, CPS, CPSK, DP+, DPK+, KPG, PKF+, HDP, HDV, HG+, LK+, LPB, LPB+, LPBK+, LPK+, NP, NPK, NPL, NPLK, NPR, NPRK, NPS, NPSK, NPT, NPTK, RP+, RPC+, RPK+, SC+, SK, SK+, SP, SP+, SPC+, SPK, SPK+, TK+, TP, TP+, TPC+, TPK, TPK+, VDH+, VDS+, VDT+, VH+, VS+, VT+, CVH, CVS, NVH, NVS, VDHe, VDSe, XP, XPC+, XPK+

Serial number: SN: 7386950, consecutive number (7-8 digits)
 Relevant statutory instrument: S.I. 2008:1597 Supply of Machinery (Safety) Regulations
 Applied designated standard: EN ISO 12100:2010
 Additionally applied standard: EN 60529:1991 + A1:2000 + A2:2013

The person authorized to compile technical documents: **WITTENSTEIN alpha GmbH**
 (address see above)

The relevant technical documentation in accordance with the requirements of Annex VII (Part 7 of Schedule 2), part B have been created. We undertake to forward the special technical documentation to a reasoned request to the national authorities. We shall submit them by means of electronic data carrier.

The designated partly completed machinery must not be put into service until the final machinery into which it is to be incorporated has been declared in conformity with the provisions of this Directive.

Igersheim, 06.12.2022

City and date



 Norbert Pastoors, Managing Director

Document No.: 1000117479

Rev.: 01



Appendix regarding the Declaration of Incorporation

List of the essential health and safety requirements applied and fulfilled for the product named in the Declaration of Incorporation.

Chapter	Designation	not applicable	fulfilled	remark
1.1.	General Remarks			
1.1.1.	Definitions		x	
1.1.2.	Principles of safety integration		x	
1.1.3.	Materials and products		x	
1.1.4.	Lighting	x		
1.1.5.	Design of machinery to facilitate its handling		x	
1.1.6.	Ergonomics	x		
1.1.7.	Operating positions	x		
1.1.8.	Seating	x		
1.2.	Control systems			
1.2.1.	Safety and reliability of control systems	x		
1.2.2.	Control devices	x		
1.2.3.	Starting	x		
1.2.4.	Stopping	x		
1.2.4.1.	Normal stop	x		
1.2.4.2.	Operational stop	x		
1.2.4.3.	Emergency stop	x		
1.2.4.4.	Assembly of machinery	x		
1.2.5.	Selection of control or operating modes	x		
1.2.6.	Failure of the power supply	x		
1.3.	Protection against mechanical hazards			
1.3.1.	Risk of loss of stability		x	
1.3.2.	Risk of break-up during operation		x	
1.3.3.	Risks due to falling or ejected objects	x		
1.3.4.	Risks due to surfaces, edges or angles		x	
1.3.5.	Risks related to combined machinery	x		
1.3.6.	Risks related to variations in operating conditions	x		
1.3.7.	Risks related to moving parts	x		
1.3.8.	Choice of protection against risks arising from moving parts	x		
1.3.8.1.	Moving transmission parts	x		
1.3.8.2.	Moving parts involved in the process	x		
1.3.9.	Risks of uncontrolled movements	x		

Document No.: 1000117479

Rev.: 01



Chapter	Designation	not applicable	fulfilled	remark
1.4.	Required characteristics of guards and protective devices			
1.4.1.	General requirements	x		
1.4.2.	Special requirements for guards	x		
1.4.2.1.	Fixed guards	x		
1.4.2.2.	Interlocking movable guards	x		
1.4.2.3.	Adjustable guards restricting access	x		
1.4.3.	Special requirements for protective devices	x		
1.5.	Risks due to other hazards			
1.5.1.	Electricity supply	x		
1.5.2.	Static electricity		x	
1.5.3.	Energy supply other than electricity	x		
1.5.4.	Errors of fitting		x	
1.5.5.	Extreme temperatures		x	
1.5.6.	Fire	x		
1.5.7.	Explosion	x		
1.5.8.	Noise		x	
1.5.9.	Vibrations		x	
1.5.10.	Radiation	x		
1.5.11.	External radiation	x		
1.5.12.	Laser radiation	x		
1.5.13.	Emissions of hazardous materials and substances		x	
1.5.14.	Risk of being trapped in a machine	x		
1.5.15.	Risk of slipping, tripping or falling	x		
1.5.16.	Lightning	x		
1.6.	Maintenance			
1.6.1.	Machinery maintenance		x	
1.6.2.	Access to operating positions and servicing points	x		
1.6.3.	Isolation of energy sources	x		
1.6.4.	Operator intervention	x		
1.6.5.	Cleaning of internal parts	x		
1.7.	Information			
1.7.1.	Information and warnings on the machinery		x	
1.7.1.1.	Information and information devices	x		
1.7.1.2.	Warning devices	x		
1.7.2.	Warning of residual risks		x	
1.7.3.	Marking of machinery		x	

Document No.: 1000117479

Rev.: 01



Chapter	Designation	not applicable	fulfilled	remark
1.7.4.	Instructions		x	
1.7.4.1.	General principles for the drafting of instructions		x	
1.7.4.2.	Contents of the instructions		x	
1.7.4.3.	Sales literature		x	

Document No.: 1000117479

Rev.: 01

Revision history

Revision	Date	Comment	Chapter
01	08.09.15	New version	All
02	23.03.18	HDV added	All
03	21.03.22	Update	All
04	26.09.2022	general revision, product conformity	All 2



WITTENSTEIN alpha GmbH · Walter-Wittenstein-Straße 1 · 97999 Igersheim · Germany
Tel. +49 7931 493-0 · info@wittenstein.de

WITTENSTEIN – one with the future

www.wittenstein-alpha.de